

Hoist and Trolley Kit must be purchased separately.

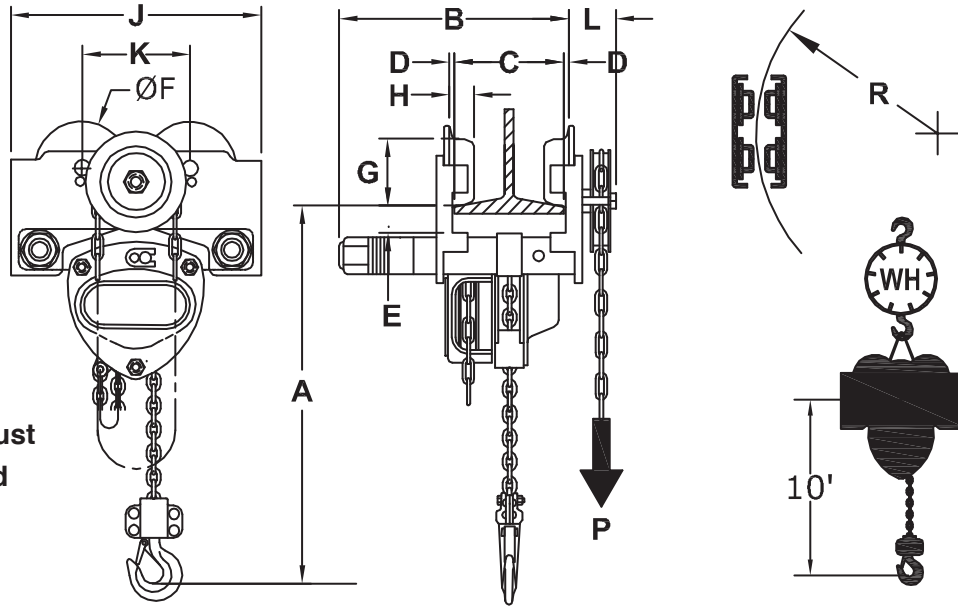

### PTL & GTL SERIES SPECIFICATION AND DIMENSIONS (inches and pounds)

Model	WLL	A	B	C	D	E	F	G	H	J	K	L	P (lbs)	R Min	Includes Hoist W(lbs)
PTL005	1/2t	11.6	9.8	2.0-8.0	0.06-0.12	1.2	3.1	2.2	0.7	10.2	3.9	3.0	----	31	46
GTL005-20													6		57
PTL010	1t	13.0	14.0	2.5-12.0	0.06-0.12	1.5	3.8	2.7	0.8	11.5	5.0	3.1	----	35	51
GTL010-20													11		62
PTL020	2t	16.1	14.3	3.5-12.0	0.06-0.12	1.5	4.3	3.1	0.9	14.2	5.4	3.3	----	39	86
GTL020-20													20		97
PTL030	3t	19.0	14.7	3.9-12.0	0.06-0.12	1.7	5.2	3.9	1.1	16.9	6.2	3.4	----	47	158
GTL030-20													21		169
PTL050	5t	25.2	15.0	4.5-12.0	0.06-0.12	1.6	5.7	4.3	1.4	17.6	6.8	3.7	----	51	222
GTL050-20													31		233
PTL075	7.5t	26.9	15.6	4.9-12.0	0.08-0.14	1.8	7.0	5.4	1.6	25.2	7.9	4.3	----	79	324
GTL075-20													42		335
PTL100	10t	30.8	15.6	4.9-12.0	0.08-0.14	1.8	7.0	5.4	1.6	25.2	7.9	4.3	----	79	342
GTL100-20													54		353

How to Order, by descriptive model number

Example: Model **GTL050 - 20**

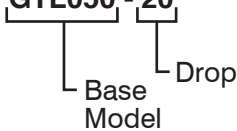

If assembly to a hoist is required then note on the order.