



AMETEK
LAMB ELECTRIC

Product Bulletin

Model: 115937

DESCRIPTION

- Two stage
- 120 volts
- 7.2"/183 mm diameter
- Double ball bearings
- Single speed
- Tangential bypass discharge
- Aluminum fan end bracket
- Aluminum commutator bracket

DESIGN APPLICATION

- Equipment operating in environments requiring separation of working air from motor ventilating air
- Designed to handle clean, dry, filtered air only

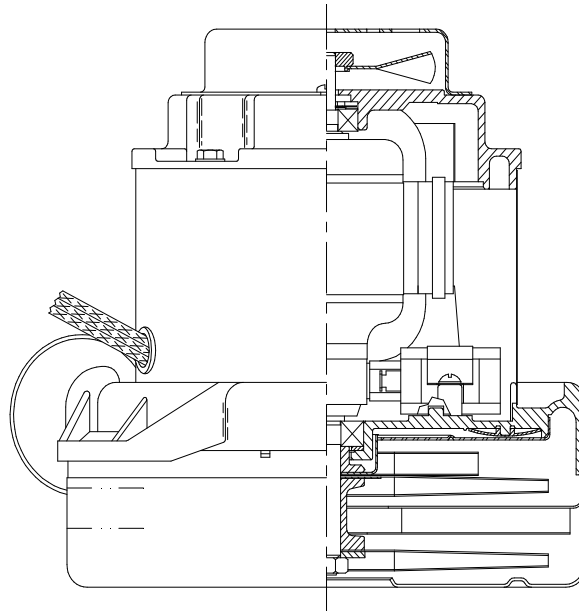

SPECIAL FEATURES

- Suitable for 120 volt AC operation, 50/60 Hz
- UL recognized, category PRGY2 (E47185)
- CSA certified, class 1611 01 (LR31393)
- Provision for grounding
- 10 mm shaft and bearing system
- Epoxy painted fan case
- Patented air seal bearing construction. U.S. Patent #4,088,424
- The Lamb Electric vacuum motor line offers a wide range of performance levels to meet design needs

TYPICAL MOTOR PERFORMANCE.*

(At 120 volts, 60Hz, test data is corrected to standard conditions of 29.92 Hg, 68° F.)

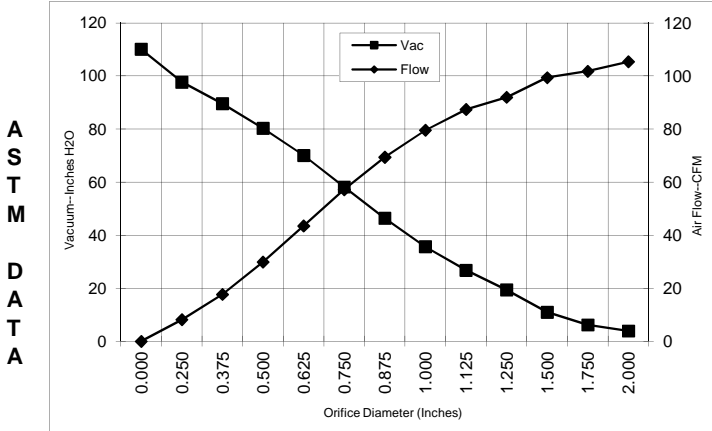

Orifice (Inches)	Amps	Watts (In)	RPM	Vac (In.H ₂ O)	Flow (CFM)	Air Watts
2.000	12.7	1405	16200	3.9	105.4	48
1.750	12.7	1405	16300	6.2	101.8	74
1.500	12.7	1405	16400	11.0	99.4	129
1.250	12.6	1403	16400	19.4	92.0	210
1.125	12.6	1395	16500	26.8	87.4	276
1.000	12.4	1380	16600	35.7	79.6	335
0.875	12.2	1354	16800	46.4	69.4	379
0.750	11.7	1313	17200	58.2	57.2	392
0.625	11.0	1252	17600	70.1	43.5	359
0.500	10.3	1170	18400	80.3	29.9	282
0.375	9.5	1082	19200	89.6	17.7	159
0.250	8.7	996	20200	97.7	8.2	95
0.000	8.3	951	21000	110.1	0.0	0

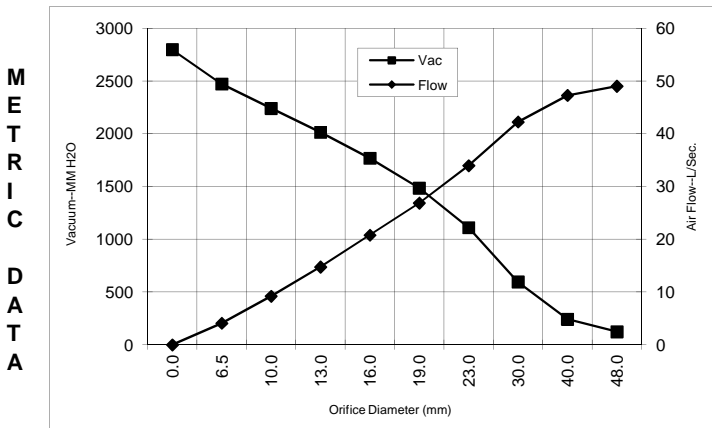

Orifice (mm)	Amps	Watts (In)	RPM	Vac (mm H ₂ O)	Flow (L/Sec)	Air Watts
48.0	12.7	1405	16244	125	49.0	59
40.0	12.7	1405	16370	243	47.3	113
30.0	12.6	1399	16455	596	42.2	246
23.0	12.3	1361	16750	1111	34.0	368
19.0	11.7	1312	17208	1484	26.9	391
16.0	11.0	1254	17584	1768	20.8	360
13.0	10.4	1178	18320	2014	14.8	290
10.0	9.6	1095	19080	2240	9.2	177
6.5	8.7	1000	20150	2471	4.1	98
0.0	8.3	951	21000	2797	0.0	0

Note: Metric performance data is calculated from the ASTM data above.

* Data represents performance of a typical motor sampled from a large production quantity. Individual motor data may vary due to normal manufacturing variations.

Test Specs:	120 volts	Minimum Sealed Vacuum:	105.0"	ORIFICE:	7/8 "	Minimum Vacuum:	42.0"	Maximum Watts:	1450
--------------------	-----------	-------------------------------	--------	-----------------	-------	------------------------	-------	-----------------------	------

DIMENSIONS

NOTES:

- 1. LEADS: POWER; #16 GA., ONE BLACK, ONE WHITE.
- GROUND; #18 GA., GREEN WITH YELLOW STRIPE.

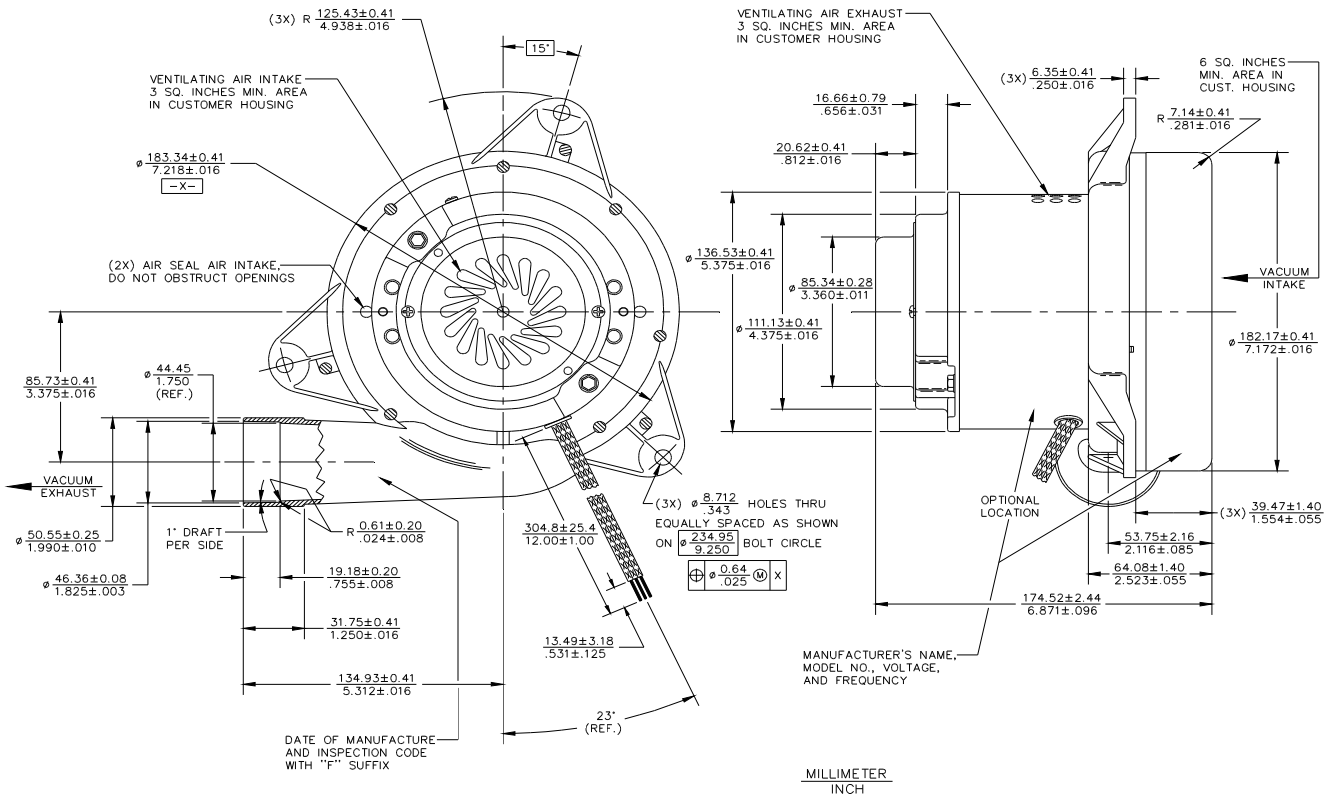

IMPORTANT NOTE: Pictorial and dimensional data are subject to change without notice. Contact factory for current revision levels.

WARNING - When using AMETEK Lamb Electric bypass motors in machines that come in contact with foam, liquid (including water), or other foreign substances, the machine must be designed and constructed to prevent those substances from reaching the fan system, motor housing, and electrical components. Lamb Electric vacuum motors other than hazardous duty models should not be applied in machines that come in contact with dry chemicals or other volatile materials. Failure to observe these precautions could cause flashing (depending on volatility) or electrical shock which could result in property damage and severe bodily injury, including death in extreme cases. All applications incorporating Lamb Electric motors should be submitted to appropriate organizations or agencies for testing specifically related to the safety of your equipment.

AMETEK/Floorcare & Specialty Motors
www.ameteksm.com