



# AMETEK LAMB ELECTRIC

## Product Bulletin

Model: 116196-00

### DESCRIPTION

- One stage
- 120 volts
- 5.7"/145 mm diameter
- Ball/Sleeve bearings
- Single speed
- Peripheral bypass discharge
- Thermoset fan end bracket
- Aluminum commutator bracket

### DESIGN APPLICATION

- Equipment operating in environments requiring separation of working air from motor ventilating air
- Designed to handle clean, dry, filtered air only

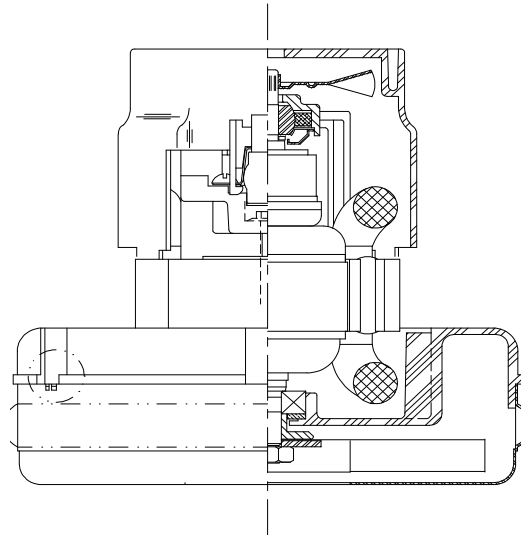

### SPECIAL FEATURES

- Suitable for 120 volt AC operation, 50/60 Hz
- UL recognized, category PRGY2 (E47185)
- CSA certified, class 1611 01 (LR31393)
- Provision for grounding
- Skeleton-frame design
- The Lamb Electric vacuum motor line offers a wide range of performance levels to meet design needs

### TYPICAL MOTOR PERFORMANCE.\*

(At 120 volts, 60Hz, test data is corrected to standard conditions of 29.92 Hg, 68° F.)

ASTM DATA

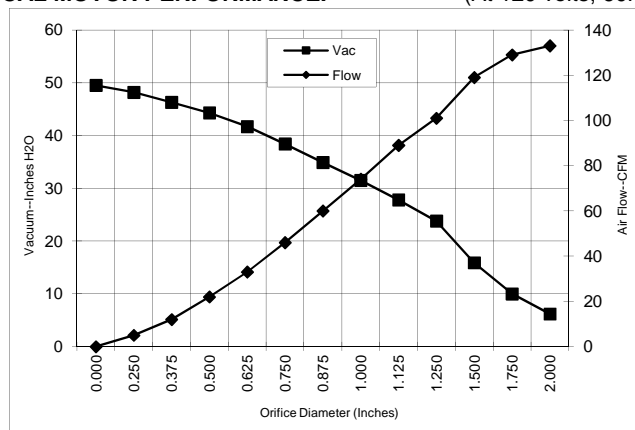

Orifice (Inches)	Amps	Watts (In)	RPM	Vac (In.H <sub>2</sub> O)	Flow (CFM)	Air Watts
2.000	7.0	820	18625	6.2	133.0	98
1.750	7.0	827	18575	10.0	129.0	153
1.500	7.0	823	18575	15.9	119.0	224
1.250	6.9	815	18800	23.8	101.0	285
1.125	6.8	798	19000	27.8	89.0	291
1.000	6.5	770	19500	31.5	74.0	278
0.875	6.3	738	19875	34.9	60.0	248
0.750	6.0	707	20450	38.4	46.0	210
0.625	5.7	682	21200	41.7	33.0	165
0.500	5.5	653	21800	44.3	22.0	115
0.375	5.3	628	22300	46.3	12.0	69
0.250	5.1	611	22800	48.2	5.0	32
0.000	4.9	589	23125	49.5	0.0	0

METRIC DATA

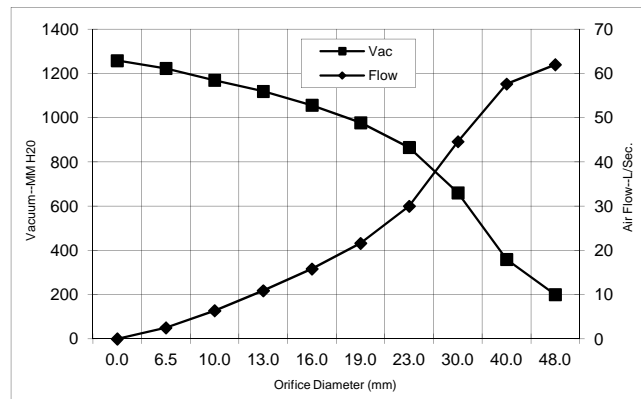

Orifice (mm)	Amps	Watts (In)	RPM	Vac (mm H <sub>2</sub> O)	Flow (L/Sec)	Air Watts
48.0	7.0	823	18603	200	61.9	122
40.0	7.0	824	18575	359	57.6	203
30.0	6.8	806	18910	660	44.6	288
23.0	6.4	746	19781	865	30.0	256
19.0	6.0	707	20465	977	21.6	209
16.0	5.7	683	21170	1056	15.8	167
13.0	5.5	656	21740	1119	10.9	120
10.0	5.3	632	22225	1168	6.4	76
6.5	5.1	612	22775	1222	2.5	34
0.0	4.9	589	23125	1257	0.0	0

Note: Metric performance data is calculated from the ASTM data above.

\* Data represents performance of a typical motor sampled from a large production quantity. Individual motor data may vary due to normal manufacturing variations.

Test Specs:	120 volts	Minimum Sealed Vacuum: 45"	ORIFICE:	7/8"	Minimum Vacuum: 32"	Maximum Watts:	850
-------------	-----------	----------------------------	----------	------	---------------------	----------------	-----

DIMENSIONS

NOTES:

1. LEADS: 18 GA STRANDED, LEADS CAN BE ANY COLOR EXCEPT GREEN OR GREEN WITH YELLOW STRIPE.
2. GROUNDING OR EARTHING PROVISIONS: USE HOLES AS INDICATED FOR GROUNDING OR EARTHING. REFER TO APPROPRIATE LISTING OR REGULATORY AGENCY FOR PROPER METHOD OF GROUNDING OR EARTHING.
3. RECOMMENDED SCREW SIZE 10-16 TYPE BT OR TYPE 25 THREAD CUTTING SCREW. MAXIMUM PENETRATION 17.40/.685.

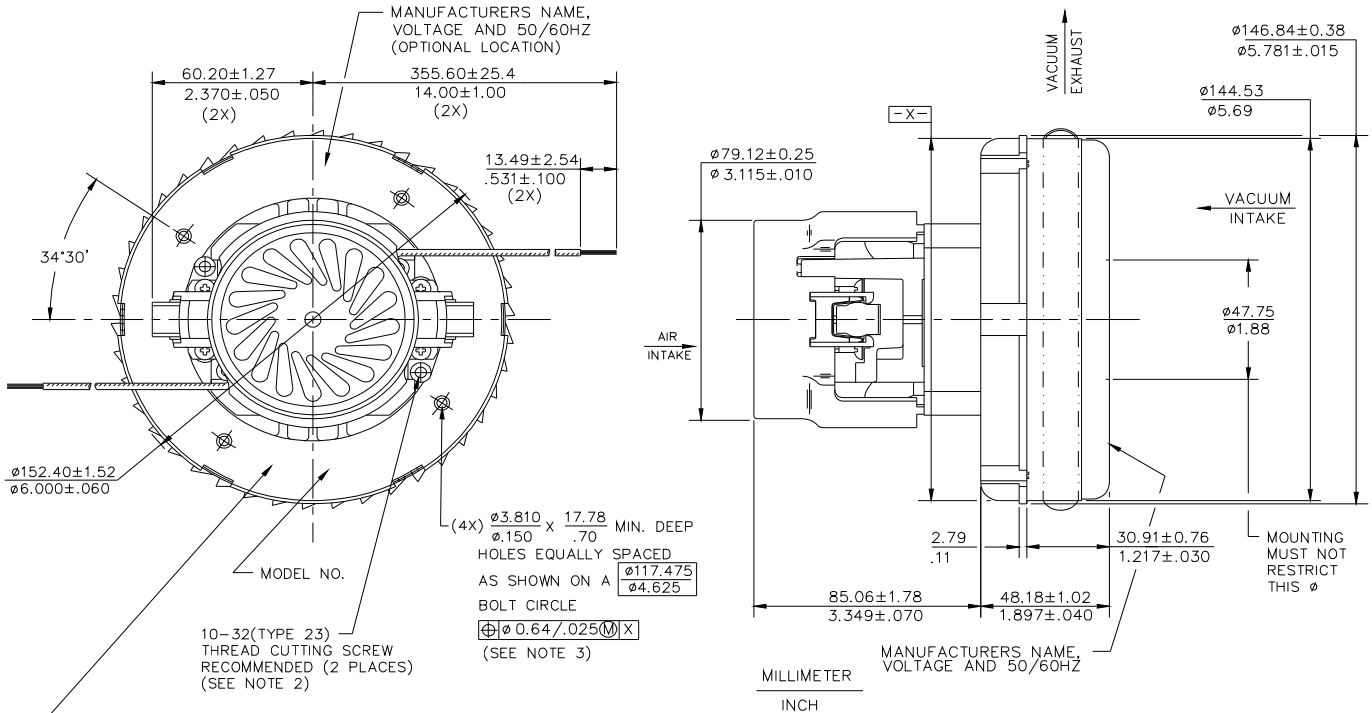

**IMPORTANT NOTE:** Pictorial and dimensional data are subject to change without notice. Contact factory for current revision levels.

**WARNING** - When using AMETEK Lamb Electric bypass motors in machines that come in contact with foam, liquid (including water), or other foreign substances, the machine must be designed and constructed to prevent those substances from reaching the fan system, motor housing, and electrical components. Lamb Electric vacuum motors other than hazardous duty models should not be applied in machines that come in contact with dry chemicals or other volatile materials. Failure to observe these precautions could cause flashing (depending on volatility) or electrical shock which could result in property damage and severe bodily injury, including death in extreme cases. All applications incorporating Lamb Electric motors should be submitted to appropriate organizations or agencies for testing specifically related to the safety of your equipment.

**AMETEK/Floorcare & Specialty Motors**  
[www.ametekfsm.com](http://www.ametekfsm.com)