

# REPLACEMENT ROLLERS

## Roller 2-1/2" Dia. x 14 Ga. with 7/16" Hex Axle - Model U

U

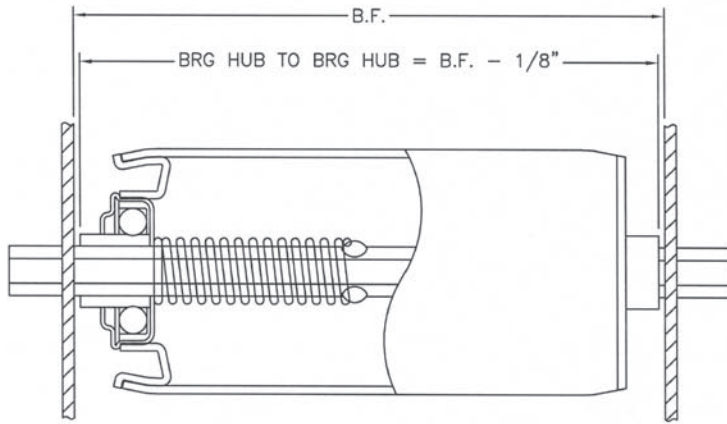

### Construction:

**Tube:** 2-1/2" O.D. x 14 ga. plain steel

**Axle:** 7/16" hex steel

**Bearing:** Light oil, swaged

**Axle Retention:** Spring retained

**Weight:** .65 + (.23 x BF)

**Shaft Length:** BF+1-5/16"

Shorter, longer, and in-between  
BF's available.

Part Number	BF	Wt. (lbs.)	Capacity (lbs.)
U07	7"	2.23	496
U08	8"	2.46	496
U09	9"	2.68	496
U10	10"	2.91	496
U11	11"	3.13	496
U12	12"	3.36	496
U13	13"	3.59	496

Part Number	BF	Wt. (lbs.)	Capacity (lbs.)
U14	14"	3.81	496
U15	15"	4.04	496
U16	16"	4.26	496
U17	17"	4.49	471
U18	18"	4.71	443
U19	19"	4.94	418
U20	20"	5.16	395
U21	21"	5.39	375
U22	22"	5.61	357
U23	23"	5.84	341
U24	24"	6.06	326
U25	25"	6.29	312
U27	27"	6.74	288
U31	31"	7.64	249
U33	33"	8.09	234
U36	36"	8.77	213
U37	37"	8.99	207
U39	39"	9.44	196
U43	43"	10.35	178
U47	47"	11.25	162
U51	51"	12.15	149

## Roller 2-1/2" Dia. x 11 Ga. with 11/16" Hex Axle - Model S

S

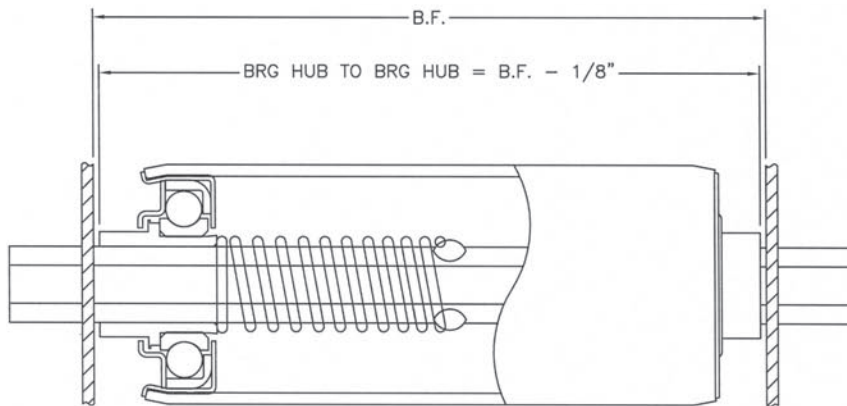

### Construction:

**Tube:** 2-1/2" O.D. x 11 ga. plain steel

**Axle:** 11/16" hex steel

**Bearing:** Light oil, swaged

**Axle Retention:** Spring retained

**Weight:** 1.08 + (.37 x BF)

**Shaft Length:** BF+1-3/4"

Shorter, longer and in-between  
BF's available.

Part Number	BF	Wt. (lbs.)	Capacity (lbs.)
S07	7"	3.67	850
S08	8"	4.04	850
S09	9"	4.41	850
S10	10"	4.78	850
S11	11"	5.15	850
S12	12"	5.52	850
S13	13"	5.89	850
S14	14"	6.26	850
S15	15"	6.63	850
S16	16"	7.00	850
S17	17"	7.37	850

Part Number	BF	Wt. (lbs.)	Capacity (lbs.)
S18	18"	7.74	850
S19	19"	8.11	850
S20	20"	8.48	850
S21	21"	8.85	850
S22	22"	9.22	850
S23	23"	9.59	850
S24	24"	9.96	850
S25	25"	10.33	850
S27	27"	11.07	850
S31	31"	12.55	850
S33	33"	13.29	850
S36	36"	14.40	846
S37	37"	14.77	822
S39	39"	15.51	777
S43	43"	16.99	702
S47	47"	18.46	640
S51	51"	19.94	587
S55	55"	21.42	543
S59	59"	22.90	505
S63	63"	24.38	472
S67	67"	25.86	443
S71	71"	27.34	417
S75	75"	28.82	394