

# CompacLift™

## X SERIES SCISSOR LIFT TABLES

Working Harder To  
Make Your Life Easier

### X Series Scissor Lift Table Dimensions

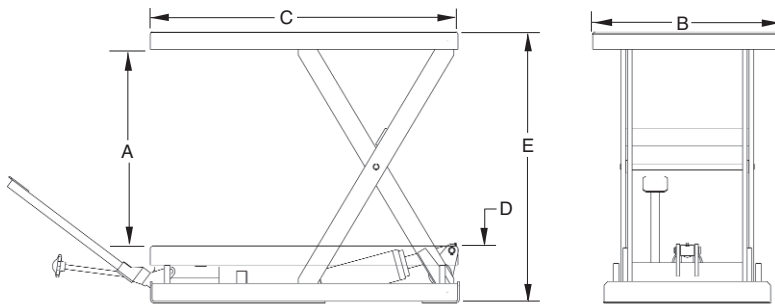

### Selector Table for X Series Lift Tables

Model	Travel (inches) (A)	Capacity (pounds)	Table Size (Inches) (B) X (C)	Height (Inches)		Strokes To Max. Height C Models	Raise Time (seconds)		Ship Weight (pounds)
				Lowered (D)	Raised (E)		Loaded	Unloaded	
X-20C	16.0	440	19.5 x 25.5	5.00	21.00	28	-	-	121
X-25C	22.0	550	19.5 x 32.0	5.00	28.00	42	-	-	157
X-25E	22.0	550	19.5 x 32.0	6.00	28.00	-	9	9	190
X-25P	22.0	550	19.5 x 32.0	6.00	28.00	-	36	-	190
X-50C	25.5	1,100	20.0 x 40.0	6.00	31.50	46	-	-	253
X-50E	25.5	1,100	20.0 x 40.0	6.00	31.50	-	12	10	285
X-50P	25.5	1,100	20.0 x 40.0	6.00	31.50	-	40	-	285
X-75C	25.5	1,650	20.0 x 40.0	6.00	31.50	67	-	-	256
X-75E	25.5	1,650	20.0 x 40.0	6.00	31.50	-	17	14	288
X-75P	25.5	1,650	20.0 x 40.0	6.00	31.50	-	58	-	288
X-30SC	45.0	660	20.0 x 40.0	9.25	54.25	54	-	-	315
X-30SE	45.0	660	20.0 x 40.0	9.25	54.25	-	14	11	345
X-30SP	45.0	660	20.0 x 40.0	9.25	54.25	-	47	-	345
X-50SE	25.5	1,100	18.0 x 25.5	8.25	33.75	-	14	11	235
X-50SP	25.5	1,100	18.0 x 25.5	8.25	33.75	-	47	-	235

C - Manual Foot Pedal Pump

E - Electric / Hydraulic 115V, 1/2HP external power unit assembly with 24VAC control voltage

P - Air / Hydraulic

S - Double Scissors

Optional foot pedal switch available on electric models.

### Standard Features

- Compact design
- Manual, electric and air operated models available
- Constructed with heavy-gauge steel and sturdy welds throughout
- Steel work platforms
- Entrapped rollers for increased stability
- Superior hydraulic systems proven on a range of Bishamon lift products
- Hand control on electric models
- Removable & storable operator's foot pedal and lowering control on manual models
- Wide range of table sizes
- Quality baked enamel finish

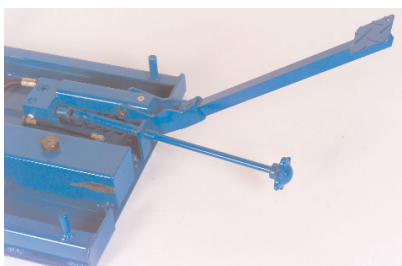

Removable & storable operator's foot pedal and lowering control on basic models.

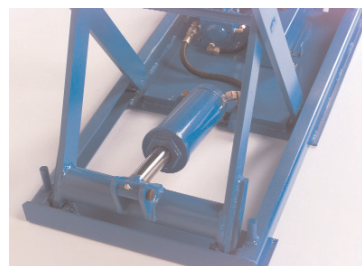

Superior hydraulic systems proven on a range of Bishamon lift products

### DISTRIBUTED BY:

**Bishamon®**

5651 East Francis Street  
Ontario, California 91761-3601

(909) 390-0055 • (800) 358-8833  
Fax (909) 390-0060

[www.bishamon.com](http://www.bishamon.com)