

100WCL & 1125WCL SERIES HAND CRANK & MOTORIZED WELDING REELS



COXREELS® 100WCL Series compact hand crank hose reels are versatile and ideal for electrode and grounding lead applications. Save time and effort while increasing the safety of your work environment. The sturdy "U" shaped frame and all steel construction make this one tough little reel. All listed models are supplied less cable.

100WCL SERIES

LESS CABLE					SIZE INDEX
MODEL	GAUGE	FT	APRX. LBS.		
112WCL-6-20	#2/0	100	19	1	
112WCL-6-10	#1/0	100	19	1	
112WCL-6-01	#1	150	19	1	
112WCL-6-02	#2	165	19	1	

COXREELS® 1125WCL Series hand crank or motorized "Welding Cable" reels are great for grounding cable. Save time and effort as you extend the life of your expensive welding cable investment. All electrical components are set inside the drum offering a special narrow width. A stacking bracket is available to create a lead/ground combination in one organized unit.

1125WCL SERIES

LESS CABLE						SIZE INDEX
MODEL	CABLE TYPE & CAPACITY				APRX. LBS.	
	#2	#1	#1/0	#2/0		
1125WCL-6-X	300 ft	250 ft	200 ft	150 ft	38	2
1125WCL-12-X	600 ft	500 ft	400 ft	300 ft	45	3

- SUFFIX "X" OPTIONS

When ordering, substitute the "X" with selection below. Add 5 lbs to ship weight if reel is crated.

SUFFIX	TYPE	DESCRIPTION	ADD ON APRX. LBS*
A	AIR - #4 GAST	COMP. AIR MOTOR	8
EB	ELEC. - 24V DC	1/2 HP REV. REV. TYPE	26
ED	ELEC. - EXPL. PRF. - 12V DC	1/2 HP REV. REV. TYPE	26
EA	ELEC. - EXPL. PRF. - 115V	1/2 HP REV., AC REV. TYPE	26
H	HYDRAULIC	END PORTED 9/16-18 UNF REV.	6
C	DIRECT HAND CRANK	STANDARD HAND CRANK	0

REEL DIMENSIONS

Technical Data Sheets Available On Website

SIZE INDEX	W			H		L	X	Y		Ø	Dw
	CRANK	ELEC.	AIR / HYD.	CRANK	ELEC.			CRANK	ELEC.		
1	18"	-	-	13"	-	12"	8"	6"	-	5-1/2"	6-1/2"
2	18 3/4"	19 7/8"	17 1/4"	18 1/2"	19 1/8"	17 1/2"	11 3/8"	15 3/8"	16"	8-1/2"	6"
3	24 3/4"	25 7/8"	23 1/4"	18 1/2"	19 1/8"	17 1/2"	17 3/8"	15 3/8"	16"	8-1/2"	12"

Overall Dimensions Base Drum

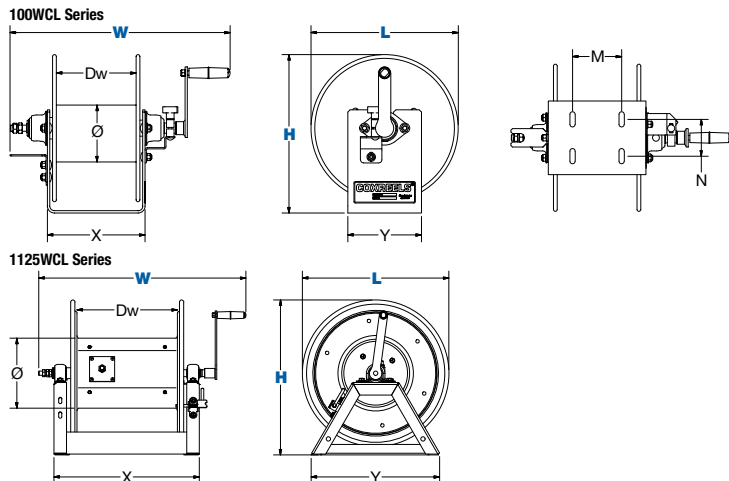

100WCL & 1125WCL SERIES :: REEL SPECIFICATIONS

100WCL & 1125WCL SLIP-RING

- Drum-located slip ring assembly for simple routine maintenance
- Electrical current runs through a 450 AMP rated slip ring

100WCL DESIGN & STRUCTURE

- Solid one piece, heavy gauge steel "U" shaped frame with open drum design
- Bronze self-lubricated spherical bearings at each end designed for heavy duty applications
- Adjustable tension brake to prevent "free-wheeling" during operation, transport or storage

100WCL RETRACTION

- Direct hand crank rewind

1125WCL DESIGN & STRUCTURE

- Designed for electrode & grounding lead applications
- All welded steel "A" frame construction for superior reel structure
- Narrow width for convenient installation in restricted spaces
- Permanently lubricated self-aligning pillow block bearings for trouble-free & smooth rotation
- Adjustable tension brake to prevent "free-wheeling" during operation
- Long-handled locking pin to secure reel from rotation during transport or storage

1125WCL RETRACTION

- Reliable direct gear drive on motor driven models
- Solid steel direct hand crank with smooth round handle
- See Motor Options Chart

SIGNATURE FEATURES

- Professional grade heavy duty steel construction
- Durable proprietary CPC™ powder coat process
- Rolled edges & ribbed discs provide strength & safety
- Leading 2-year manufacturer's limited warranty
- Made in the U.S.A. - Sold & Supported Worldwide

POSSIBLE FIELDS OF APPLICATION

- Manufacturing Plants
- Maintenance, Repair & Operations
- Welding / Service Trucks
- Welding Shops
- Pipelines
- Mining, Construction & Railroad Operations
- Marine/Ship Building/ Offshore

ACCESSORIZE YOUR REEL :: PG 50

- Stacking Brackets
- Assorted Reel Accessories
- Roller Bracket

