

®  
**Dayton**



## **10" Right Tilt Table Saw**

**Model 49G995**

®  
**Dayton**

**PLEASE READ AND SAVE  
THESE INSTRUCTIONS.  
READ CAREFULLY  
BEFORE ATTEMPTING  
TO ASSEMBLE, INSTALL,  
OPERATE OR MAINTAIN THE  
PRODUCT DESCRIBED.**

**PROTECT YOURSELF AND  
OTHERS BY OBSERVING ALL  
SAFETY INFORMATION. FAILURE  
TO COMPLY WITH INSTRUCTIONS  
COULD RESULT IN PERSONAL  
INJURY AND/OR PROPERTY  
DAMAGE! RETAIN INSTRUCTIONS  
FOR FUTURE REFERENCE.**

**PLEASE REFER TO BACK COVER  
FOR INFORMATION REGARDING  
DAYTON'S WARRANTY  
AND OTHER IMPORTANT  
INFORMATION.**

**Model #:** \_\_\_\_\_

**Serial #:** \_\_\_\_\_

**Purch. Date:** \_\_\_\_\_

*Form 5S7589 / Printed in Taiwan*

*04634 Version 0.0 09/2014*

*© 2014 Dayton Electric Manufacturing Co.*

*All Rights Reserved*

## GETTING STARTED

### Structural requirements



Make sure all supporting structures and load attaching devices are strong enough to hold your intended loads. If in doubt, consult a qualified structural engineer.

### Electrical requirements



The power supply to the Table Saw needs to be 240 volt/ 16 amp, single phase, 60 Hz. The standard allowable voltage variation is plus or minus 10%.

### Tools Needed:

Standard mechanic's hand tool set.

## UNPACKING

**⚠ WARNING** *Be careful not to touch overhead power lines, piping, lighting, etc. if lifting equipment is used. Table Saw weighs approximately 490 lbs, proper tools, equipment and qualified personnel should be employed in all phases of unpacking and installation.*

Crates should be handled with care to avoid damage from dropping, bumping, etc. Store and unpack crates with correct side up. After uncrating Table Saw, inspect carefully for any damage that may have occurred during transit. Check for loose, missing or damaged parts. If any damage or loss has occurred, claim must be filed with carrier immediately. Check for completeness. Immediately report missing parts to dealer.

Table Saw is shipped partially assembled. End user will need to assemble loose parts to machine.

**IMPORTANT:** The tool has been coated with a protective coating. In order to ensure proper fit and operation, the coating must be removed. Remove coating with mild solvents such as mineral spirits and a soft cloth. Nonflammable solvents are recommended. After cleaning, cover all exposed metal surfaces with a light coating of oil.

**⚠ CAUTION** *Never use highly volatile solvents. Avoid getting cleaning solution on paint as it may tend to deteriorate these finishes. Use soap and water on painted components.*

### Carton no. 1 contains:

- Table extension (2)
- Cabinet door (1)
- Miter gauge assembly (1)
- Blade guard assembly (1)
- Anti-kickback pawl assembly (1)
- Locking knob (2)
- Handwheel and crank handle assembly (2)
- Arbor wrench (1)
- Dado insert assembly (1)
- T-Blocks with 6-1.0 x 20mm socket head bolt (2)
- 5/8" Dado arbor (1)

- 10-1.5 x 35mm Hex head bolt with lock washer (6)
- Push stick (1)
- 10" Blade (1)
- Operating Instructions and Parts Manual (1)

**NOTE:** 5/8" Arbor, Nut and Flange are installed on saw.

### Carton no. 2 contains:

- Rip Fence Assembly (1)
- Front, Rear and Guide Rails (1)
- Scale (1)
- Hardware Bag (1)

### Carton no. 3 contains:

- Extension Table (1)
- Support Bar (1)
- Legs (2)
- Hardware Bag (1)

### Unpack:



• Unbolt saw from pallet and carefully lift saw from pallet using appropriate hoisting equipment. Do not discard packing materials until after machine has been inspected for damage and completeness. Locate loose parts and set aside.

### Inspect:



- After unpacking the unit, carefully inspect for any damage that may have occurred during transit. Check for loose, missing or damaged parts. Shipping damage claims must be filed with the carrier.
- All tools should be visually inspected before use, in addition to regular periodic maintenance inspections.
- Be sure that the voltage labeled on the unit matches your power supply.



• See General Safety Instructions, Cautions and Warnings as shown.

## SAFETY RULES

**⚠ WARNING** *For your own safety, read all of the instructions and precautions before operating tool.*



**PROPOSITION 65 WARNING:** Some dust created by using power tools contain chemicals known to the state of California to cause cancer, birth defects or other reproductive harm.

Some examples of these chemicals are:

- Lead from lead-based paints.
- Crystalline silica from bricks and cement and other masonry products.
- Arsenic and chromium from chemically-treated lumber.

## SAFETY RULES (CONTINUED)

Your risk from these exposures varies, depending on how often you do this type of work. To reduce your exposure to these chemicals: work in a well ventilated area and work with approved safety equipment. Always wear OSHA/NIOSH approved, properly fitting face mask or respirator when using such tools.

**▲ WARNING** *Always follow proper operating procedures as defined in this manual even if you are familiar with the use of this or similar tools. Remember that being careless for even a fraction of a second can result in severe personal injury.*

### Be prepared for job

- Wear proper apparel. Do not wear loose clothing, gloves, neckties, rings, bracelets or other jewelry which may get caught in moving parts of machine.
- Wear protective hair covering to contain long hair.
- Wear safety shoes with non-slip soles.
- Wear safety glasses complying with United States ANSI Z87.1. Everyday glasses have only impact resistant lenses. They are **NOT** safety glasses.
- Wear face mask or dust mask if operation is dusty.
- Be alert and think clearly. Never operate power tools when tired, intoxicated or when taking medications that cause drowsiness.

### Prepare work area for job

- Keep work area clean. Cluttered work areas invite accidents.
- Do not use power tools in dangerous environments. Do not use power tools in damp or wet locations. Do not expose power tools to rain.
- Work area should be properly lighted.
- Proper electrical receptacle should be available for tool. Three-prong plug should be plugged directly into properly grounded, three-prong receptacle.
- Extension cords should have a grounding prong and the three wires of the extension cord should be of the correct gauge.
- Keep visitors at a safe distance from work area.
- Keep children out of workplace. Make workshop childproof. Use padlocks, master switches or remove switch keys to prevent any unintentional use of power tools.

### Tool should be maintained

- Always unplug tool prior to inspection.
- Consult manual for specific maintaining and adjusting procedures.
- Keep tool lubricated and clean for safest operation.
- Remove adjusting tools. Form habit of checking to see that adjusting tools are removed before switching machine on.
- Keep all parts in working order. Check to determine that the

guard or other parts will operate properly and perform their intended function.

- Check for damaged parts. Check for alignment of moving parts, binding, breakage, mounting and any other condition that may affect a tool's operation.
- A guard or other part that is damaged should be properly repaired or replaced. Do not perform makeshift repairs. (Use parts list provided to order repair parts.)

### Know how to use tool

- Use right tool for job. Do not force tool or attachment to do a job for which it was not designed.
- Disconnect tool when changing the blade.
- Avoid accidental start-up. Make sure that the tool is in the OFF position before plugging in.
- Do not force tool. It will work most efficiently at the rate for which it was designed.
- Keep hands away from moving parts and cutting surfaces.
- Never leave tool running unattended. Turn the power off and do not leave tool until it comes to a complete stop.
- Do not overreach. Keep proper footing and balance.
- Never stand on tool. Serious injury could occur if tool is tipped or if blade is unintentionally contacted.
- Know your tool. Learn the tool's operation, application and specific limitations.
- Use recommended accessories. Use of improper accessories may cause risk of injury to persons.
- Handle workpiece correctly. Protect hands from possible injury.
- Turn machine off if it jams. Blade jams when it digs too deeply into workpiece. (Motor force keeps it stuck in the work.) Do not remove jammed or cut off pieces until the saw is turned off, unplugged and the blade has stopped.
- Feed work into the blade against the direction of rotation of the blade only as recommended in "Operation".

**▲ WARNING** *For your own safety, do not operate your saw until it is completely assembled and installed according to instructions and until you have read and understand the following.*

### Stability of saw

If there is any tendency for the saw to tip over or move during certain cutting operations, such as cutting extremely heavy panels or long heavy boards, the saw should be bolted down. If you attach any kind of extensions over 24" wide to either end of the saw, make sure you either bolt the saw to the floor, as appropriate, or support the outer end of the extension from the bench or floor, as appropriate.

### Location

The saw should be positioned so neither the operator nor a casual observer is forced to stand in line with the saw blade.

## SAFETY RULES (CONTINUED)

### Kickbacks

A kickback occurs during a rip-type operation when a part or all of workpiece is thrown back violently toward operator.

Keep your face and body to one side of the saw blade, out of line with a possible kickback.

Kickbacks and possible injury from them can usually be avoided by:

- Maintaining rip fence parallel to saw blade.
- Keeping saw blade sharp. Replace or sharpen anti-kickback pawls when points become dull.
- Keeping saw blade guard, spreader, and anti-kickback pawls in place and operating properly. The spreader must be in alignment with the saw blade and the pawls must stop a kickback once it has started. Check their action before ripping.
- Not ripping work that is twisted or warped or does not have a straight edge to guide along the rip fence.
- Not releasing work until you have pushed it all the way past the saw blade.
- Using a push stick for ripping widths less than 6".
- Not confining the cutoff piece when ripping or crosscutting.

### Protection: eyes, hands, face, body, ears

- If any part of your saw is missing, malfunctioning or has been damaged or broken (such as the motor switch, electronic controls, other operating control, a safety device or power cord), cease operating immediately until the particular part is properly repaired or replaced.
- Wear safety goggles that comply with United States ANSI Z87.1 and a face shield or dust mask if operation is dusty. Wear ear plugs or muffs during extended periods of operation.
- Small loose pieces of wood or other objects that contact the rear of the revolving blade can be thrown back at the operator at excessive speed. This can usually be avoided by keeping the guard and spreader in place for all through-sawing operations (sawing entirely through work) and by removing all loose pieces from the table with a long stick of wood immediately after they are cut off.
- Use extra caution when the guard assembly is removed for resawing, dadoing, or rabbeting—replace guard as soon as that operation is completed.
- For rip or rip-type cuts, the following end of a workpiece to which a push stick or push board is applied must be square (perpendicular to the fence) in order that feed pressure applied to the workpiece by the push stick or block does not cause the workpiece to come away from the fence, and possibly cause a kickback.
- During rip and rip-type cuts, workpiece must be held down on table and against fence with a push stick, push block, or featherboards, as applicable (see Figures 1 and 2, pages 3 and 4). A push stick is a safety device used to push the

workpiece through a cutting operation. Used most often when rip cutting thin workpieces.

- Never turn the saw ON before clearing the table of all tools, wood scraps, etc., except the workpiece and related feed or support devices for the operation planned.
- Never place your face or body in line with the cutting tool.
- Never place your fingers or hands in path of saw blade or other cutting tool.
- Never reach in back of the cutting tool with either hand to hold down or support the workpiece, remove wood scraps, or for any other reason. Avoid awkward operations and hand positions where a sudden slip could cause fingers or hand to move into a saw blade or other cutting tool.
- Do not perform layout, assembly, or setup work on the table while the cutting tool is rotating.
- Do not perform any operation freehand—always use either rip fence or miter gauge to position and guide the work.
- Never use the rip fence when cross-cutting or the miter gauge when ripping. Do not use rip fence as a length stop. Never hold onto or touch free-end of workpiece or a free-piece that is cut off, while power is on and/or saw blade is rotating.
- Shut the saw OFF and disconnect power source when removing the table insert, changing the cutting tool, removing or replacing the blade guard, or making adjustments.

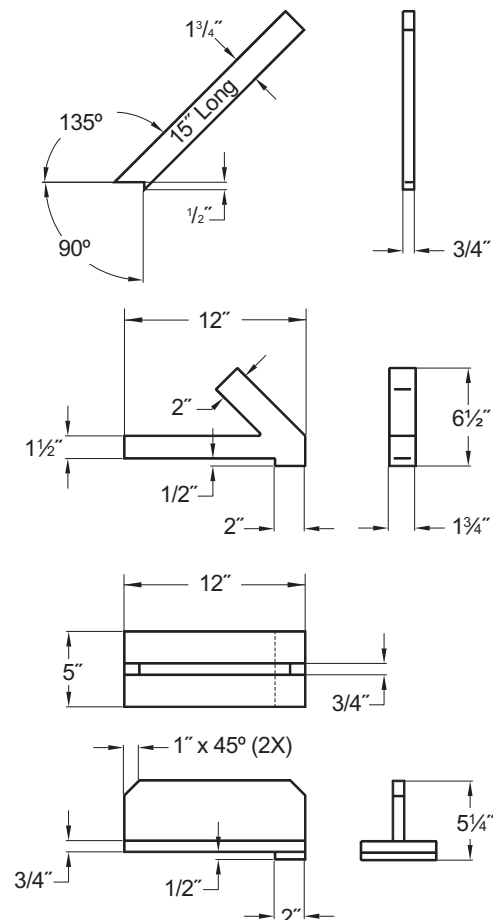
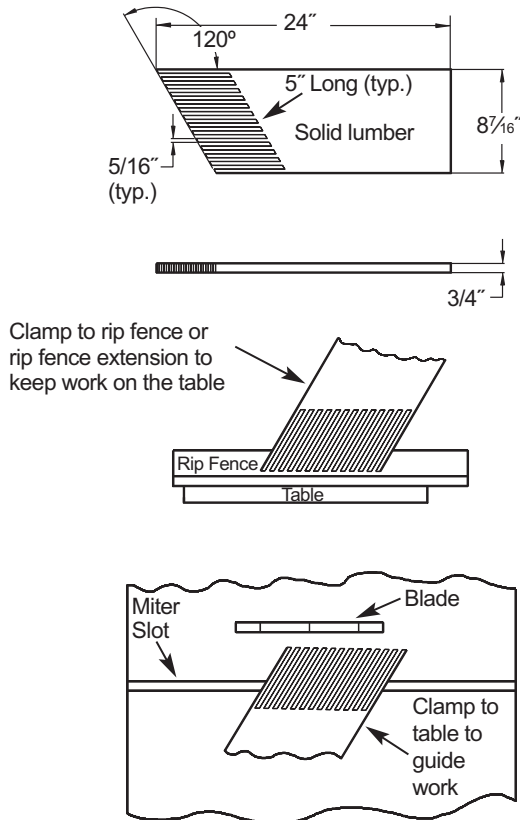

Figure 1 – Push sticks and push blocks

## SAFETY RULES (CONTINUED)



**Figure 2 – Featherboards**

- To prevent unauthorized use, lock the start switch using provided padlock.
- Provide adequate support to the rear and sides of the saw table for wide or long workpieces.
- Plastic and composition materials (like hardboard) may be cut on your saw. However, since these are usually quite hard and slippery, the anti-kickback pawls may not stop a kickback. Therefore, be especially attentive to following proper setup and cutting procedures for ripping. Do not stand, or permit anyone else to stand, in line with a potential kickback.
- If you stall or jam the saw blade in the workpiece, turn saw OFF and remove the workpiece from the saw blade. Check to see if the saw blade is parallel to the miter gauge grooves and if the spreader is in proper alignment with the saw blade. If ripping at the time, check to see if the rip fence is parallel with the saw blade. Readjust as required.
- Do not remove small pieces of cutoff material that may become trapped inside the blade guard while the saw is running. This could endanger your hands or cause kickback. Turn saw off and wait until blade stops.
- Use extra care when ripping wood with twisted grain or wood that is twisted or bowed—it may rock on table and pinch saw blade.

### Know your cutting tools

- Dull, gummy, improperly sharpened or set cutting tools can cause material to stick, jam, stall saw, or kickback at operator. Minimize potential injury by proper care and machine maintenance.

**▲ WARNING** *Never attempt to free a stalled saw blade without first turning saw OFF.*

- Never use grinding wheels, abrasive cutoff wheels, friction wheels (metal slitting blades), wire wheels or buffing wheels.

### Use only accessories designed for saw

- Crosscutting operations are worked more conveniently and with greater safety if an auxiliary wood facing is attached to miter gauge using holes provided. However, facing must not interfere with proper functioning of saw blade guard.
- Make sure the top of the arbor or cutting tool rotates toward you when standing in normal operating position. Also make sure the cutting tool, blade flange and arbor nut are installed properly. Keep the cutting tool as low as possible for the operation being performed. Keep all guards in place whenever possible.
- Do not use any blade or other cutting tool marked for operating speed less than 4000 RPM. Never use a cutting tool larger in diameter than diameter for which saw was designed. For greatest safety and efficiency when ripping, use maximum diameter blade for which saw is designed, since under these conditions spreader is nearest the blade.
- Adjust table inserts flush with table top. Never operate saw unless proper insert is installed.
- Never feed material into the cutting tool from the rear of the saw. An accident and serious injury could result.

### Think safety

Safety is a combination of operator common sense and alertness at all times when the saw is being used.

Never use another person as a substitute for a table extension, or as additional support for a workpiece that is longer or wider than basic saw table, or to assist in feeding, supporting or pulling the workpiece.

Do not pull the workpiece through the saw blade—position your body at the infeed side of the guard; start and complete the cut from that same side. This will require added table support for long or wide workpieces that extend beyond the length or width of the saw table.

**▲ CAUTION** *Follow safety instructions that appear on the front of your saw.*

**▲ CAUTION** *Think safety! Safety is a combination of operator common sense and alertness at all times when tool is being used.*

## SPECIFICATIONS

Depth of cut at 90°	3"
Maximum tilt angle of arbor	45°
Depth of cut at 45°	2 1/8"
Max. cut right of blade with rip fence	50"
Max. cut left of blade with rip fence	10"
Table height	34"
Cabinet depth	19 1/2"
Cabinet width	21 1/2"
Table area	37 x 27"
Front of table to blade	12"
Rip fence	36 5/8"
Rip fence rails (front and rear)	77, 73"
Blade capacity maximum	10"
Blade arbor extension	5/8"
Dado blade capacity maximum	13/16"
Dado blade arbor extension	5/8"
Cabinet	Totally enclosed welded steel
Table	Solid cast iron
Rip fence	Aluminum and steel tube
Drive system	3 V-belts
Exhaust port	4" Male
Miter gauge	Cast iron with a T-slot roller guide
Blade guard	Acrylic with anti-kickback pawls
Switch	Locking magnetic starter with overload
Arbor RPM	4,000 RPM approx.
Motor	3HP, 3450 RPM, capacitor start, capacitor run, 230V, 16A, single-phase, ball bearing
Gross weight with motor	490 lbs

## ASSEMBLY

Refer to Figures 3 – 12.

**CAUTION** Do not attempt assembly if parts are missing. Use this manual to order repair parts.

Be certain all parts are clean and free of shipping preservative. Also, completely remove all parts of crate and packing. Saw cabinet should be directly on the floor.

### Saw installation

Positioning the saw on a level surface (shimming may be required) will improve stability and accuracy and prevent warpage and failure of cast components and welds. Level the saw using shims or machine mounts. The stationary saw base is fitted with four mounting holes. The holes are located within an orange recess. Use these holes to secure stationary saw to the floor. This saw should be permanently fastened to the floor. This will decrease vibration and increase stability.

**DANGER** The drive pulley and motor pulley furnished, will run the blade at approximately 4000 RPM when used with 3500 RPM motor. Never substitute these pulleys to increase this speed because it could be dangerous.

### Blade installation

Refer to Figure 9.

**NOTE:** Saw is supplied with a 10" x 5/8" x 40T blade.

**WARNING** Turn the power switch to "OFF" and unplug the power cord from its power source when changing the saw blade.

**WARNING** When replacing blades, check the thickness stamped onto the riving knife. You must select a blade with a kerf width larger than the thickness of the riving knife. The kerf width should be marked on the blade or blade package. Thinner blades may cause the workpiece to bind during cutting.

This saw has a 2.5mm thick riving knife. Only use for 10" diameter blade with 3.0mm min. kerf width and 2.0mm max. body thickness.

1. Remove arbor nut and blade flange (Ref. Nos. 37 and 38) from the arbor.
2. Check that arbor diameter matches mounting hole of blade. Saw is supplied with a 5/8" standard arbor.
3. Mount blade onto the arbor. Be sure blade is mounted so that it spins in proper direction. Replace arbor flange and nut. Tighten nut securely.

**IMPORTANT:** Blade rotates towards front of saw. When installing blade, make sure teeth are pointing towards front of the saw.

**NOTE:** Do not over tighten arbor nut. Use the arbor wrench to just "snug" it.

### Assemble handwheels

Refer to Figures 10 and 11.

1. Both handwheels are identical. Attach crank handles (Figure 11, Ref. No. 13) securely to handwheels (Figure 11, Ref. No. 27).
2. Handwheels are attached to tilt adjustment shaft (Figure 10, Ref. No. 4) and height adjustment shaft (Figure 10, Ref. No. 24).
3. Place key (Figure 10, Ref. No. 6) in keyway. Assemble handwheel to shaft engaging set screw (Figure 11, Ref. No. 28) with key in shaft. Position hand wheel onto shaft as far as possible without interfering with movement. Tighten set screw.
4. Install locking knobs (Figure 11, Ref. No. 23). Insert threaded portion of knobs into end of shafts. Gently hand tighten until it stops. This is locked position. To unlock, back out knob three complete turns. For now, leave handwheels unlocked.

**NOTE:** Do not over tighten locking knobs.

## ASSEMBLY (CONTINUED)

### Check table alignment

Refer to Figures 3 and 11.

1. Saws are shipped from the factory with the table adjusted so the miter gauge slots are parallel to the saw blade. However, in order to obtain the best results from the saw, it is suggested this adjustment be checked before operating.
2. A simple method of checking alignment is as follows: Bolt or clamp a dowel rod or similar object to miter gauge (a combination square can be substituted). Pick out a tooth on front of blade and set the dowel to it so it is just touching. Move same tooth to back of blade.
3. Gauge this tooth with the dowel rod. If the tooth is in the same position, relative to the miter gauge, the table is parallel with the blade. In short, the miter gauge slots must be parallel with the blade. This means that when measuring distance between blade and slot at the front and rear of the blade, the distances will be equal (See Figure 3).

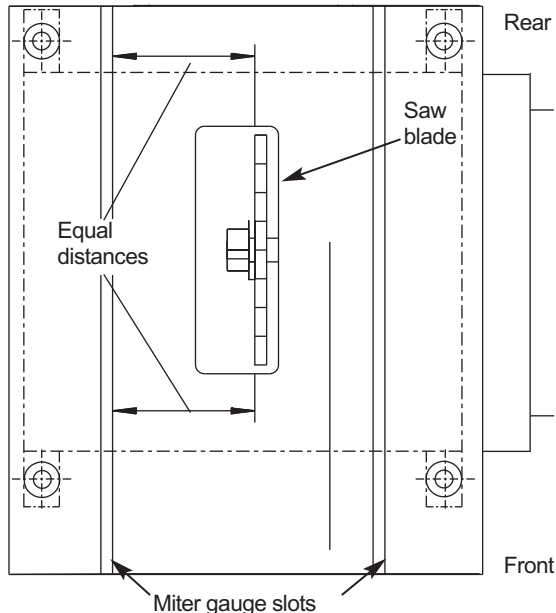

**Figure 3 – Aligning Miter Slots to Blade**

**NOTE:** Be positive to measure the distance or make the test on the same tooth of the saw blade in both front and rear positions.

4. If an adjustment is necessary, proceed as follows: (Refer to Figures 3 and 11). Loosen the hex head bolts and lock washers (Figure 11, Ref. Nos. 10 and 4) to the base (Figure 11, Ref. No. 11). Shift the table until a position is found where the saw blade is parallel to the miter gauge slots.

**NOTE:** Saw blade should also be centered within its table insert opening.

5. Tighten four hex head bolts and lock washers (Figure 11, Ref. Nos. 10 and 4) very securely. This procedure will set the table in parallel position and prevent the table from shifting.

### Mount table extensions

Refer to Figure 11.

1. Be certain both edges of table (Ref. No. 1) and table extension (Ref. No. 2) are clean and free from any preservative, debris or burrs.
2. Attach each table extension with three hex head bolts and lock washers and flat washers (Ref. Nos. 3, 4 and 29). Fasten the hex head bolts and lock washers to matching tapped holes in table. Hand tighten.
3. Using a straightedge, set top of extension flush with the table top. Extension should also be centered front to rear. First, slightly tighten the center bolt. If either end is not flush, tap extension up or down with rubber mallet. Bring extension in line with table. Securely tighten one bolt at a time, keeping extension flush with table top.

### Mount rip fence rails and extension table

Refer to Figures 11 and 12.

1. Attach rip fence front rail (Fig. 12, No. 6) to front of table (Fig. 11, No. 1). Rails will extend out approximately 36" from right side of saw.

**NOTE:** Front rail is 2 x 2", rear rail is 1½ x 1½".

2. Place front rail, oriented as shown in Figure 12, against the table and locate the holes in the table. Fasten rail to table with flat head screws (Fig. 12, No. 7) and with washers and nuts (Fig. 12, Nos. 27, 28 and 29) on the inside of the table. Finger tighten loosely. Tighten securely after all fasteners have been attached.
3. Place rear rail (Fig. 12, No. 31), oriented as shown in Figure 12, against the table and locate the holes in the table. Place hex head bolt (Fig. 12, No. 32) through hole in rail, through spacer (Fig. 12, No. 30), and then through hole in table. Secure with washers and hex nut (Fig. 12, Nos. 27, 28 and 29) inside table. Finger tighten loosely. Tighten securely after all fasteners have been attached.
4. Attach one 8mm hex nut and foot to each leg (Fig 12, Nos. 38, 39 and 22).
5. Attach each leg to the support bar using two 8mm hex head bolts and lock washers (Fig. 12, Nos. 4, 5 and 41). Set this assembly aside.
6. Position extension table (Fig. 12, No. 40) between the table saw rails, with the holes in the table and rails aligned.

**NOTE:** The notch in the table should be positioned at the right side of the front rail. Use clamps to secure table or have another person support table.

7. Secure extension table to the front rail using two 8mm flat head screws, flat washers and hex nuts (Fig. 12, Nos. 36, 37 and 38). Secure the left side of the extension table to the rear rail using a 10 x 35mm hex head bolt, flat washer and hex nut (Fig. 12, Nos. 32, 27 and 29). Secure the right side of the extension table to the rear rail using a 10 x 70mm hex head bolt, flat washer and hex nut (Fig. 12, Nos. 35, 27 and 29).



## ASSEMBLY (CONTINUED)

- Place the guide rail (Fig. 12, No. 2) on top of the front rail at this time. Do not attach scale to guide rail at this time.
- Place a hex nut and flat washer (Fig. 12, Nos. 27 and 29) onto the 10 x 70mm hex head bolt. Position the leg-support bar assembled previously underneath table and with the 10 x 70mm hex head bolt through the vertical bend of the support bar. Align holes in the support bar, front rail and guide rail. Secure with 8mm hex head bolt and lock washer (Fig. 12, Nos. 4 and 5).
- Completely secure guide rail to front rail using five hex head bolts (Fig. 12, Nos. 2, 4, 5 and 6).
- Place a hex nut and flat washer (Fig. 12, Nos. 27 and 29) onto the 10 x 70mm hex head bolt. Tighten hex nuts securely on both sides of the vertical bend of the support bar.
- Adjust feet level to floor and secure in position with hex nuts.

### Scale installation

Refer to Figure 12.

- Position left side of rip fence against right side of blade. Mark the guide rail (No. 2) at the zero position indicated by red line on lens (No. 20).
- Remove the rip fence and apply a strip of masking tape along the guide rail 1/4" deep from front edge of rail.
- Using the zero mark as the starting point and the masking tape as a guide, apply the adhesive scale (No. 1) to guide rail. Press scale firmly into place using heavy finger pressure.

### Rip fence assembly installation

Refer to Figure 12.

- Position rip fence assembly at end of saw. Be certain locking lever (Ref. No. 14) is in UP unlocked position.
- Place rip fence assembly onto rails, positioning plastic pad (Ref. No. 24) on rear rail (Ref. No. 31), and then placing rip fence onto guide rail (Ref. No. 2).
- Rip fence should now ride freely on rip fence rails. Once rip fence is completely installed, it should be thoroughly adjusted. (See Operation, page 11, "Rip Fence Adjustment".)

### Position and adjust riving knife

Refer to Figure 9.

- Riving knife is installed on the saw. Raise the blade completely to access the riving knife.
- Loosen the locking wing nut (Ref. No. 26) and raise the riving knife to its highest position. Riving knife has two holes for two positions. The highest position is for all thru cuts. The lowest position is for dado cuts.
- Make sure locking pin (Ref. No. 19) is aligned with riving knife hole and secure in position by tightening wing nut.

- Riving knife must be in line with blade. Make sure riving knife sits flat against mounting bracket and lock plate.

### Riving knife to blade adjustment

Refer to Figure 9.

- Riving knife to blade clearance: the gap between the riving knife and the saw blade should be an even distance across the entire radius.
- The riving knife should also be in line with the saw blade. If adjustment is necessary:
  - Locate the riving knife bracket (Ref. No. 21).
  - Loosen the two socket head cap screws (Ref. No. 13) slightly enough to move the bracket, bringing the riving knife in line with the saw blade. Make sure the gap between the blade and knife is even and from 1/4 to 5/16" in distance.
  - Once the riving knife is aligned with the blade, tighten the socket head cap screws.

### Table inserts installation

Refer to Figure 11.

- Be certain blade insert (Ref. No. 5) and dado insert (Ref. No. 6) are clean. Lower blade below table. Place blade insert into position with cut-out on blade side.
- Surface of insert should be flush with table surface. Using a straightedge, check insert to see if it is flush with table. To adjust insert, remove insert from table and turn it upside down on work bench.
- Each corner of table insert is fitted with an adjusting set screw. Adjust each corner of insert up or down to bring insert flush with table top. Be certain all four set screws are firmly seated on table casting.
- Repeat procedure for dado insert (Ref. No. 6). Replace blade insert (Ref. No. 5).

**CAUTION** *Only use dado insert (Figure 10, Ref. No. 6) with dado blade set. Only use blade insert (Figure 10, Ref. No. 5) with standard blade. Never attempt to interchange; only use table insert with the blade it was intended to be used with.*

### Attach blade guard and anti-kickback pawls

Refer to Figures 4 and 5, page 8.

- Place the slot of blade guard body over the riving knife.
- Insert the rear pin of the blade guard into the middle notch of the riving knife, then insert the front pin at the blade guard into the front notch of the riving knife.
- Tighten the wing nut to secure blade guard in position.
- Place anti-kickback pawl set onto riving knife at notch indicated.

**ASSEMBLY (CONTINUED)**

5. Press pawl set completely down and tighten wing nut in position.

**NOTE:** The teeth of anti-kickback pawls should touch table

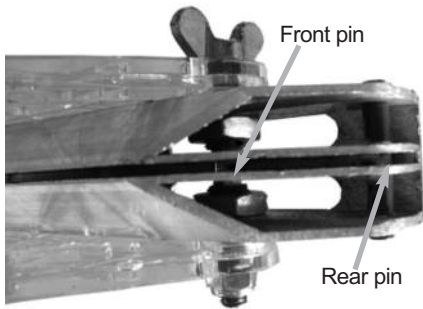

**Figure 4 – Blade guard has two pins. insert rear pin into riving knife first. then insert front pin into riving knife.**

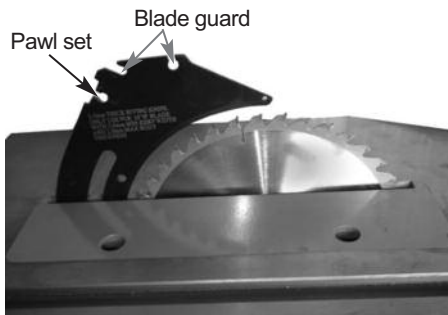

**Figure 5 – Riving knife**

surface.

**Install miter gauge**

Refer to Figure 11.

1. The miter gauge comes pre-assembled. Unpack the miter gauge and clean thoroughly. Be certain miter gauge T-slots in table are also thoroughly cleaned.
2. The miter gauge is guided through the T-slot with a roller guide at the front of guide bar. To insert miter gauge, first insert roller guide into T-slot at front of table.

**Assemble door**

Refer to Figure 11.

Loosen four pan head screws (No. 24) located on cabinet. Place door (No. 12) over and onto screws. Secure in position.

**INSTALLATION**

Refer to Figure 6., page 9.

**Electrical connections**

**▲ WARNING** *Be certain switch is in OFF position. Disconnect the source of all power. Keep circuit breaker open or in OFF position.*

Dayton 10" saw comes with motor installed and prewired for 240V, single phase operation. If saw does not operate properly, have a qualified electrician check all electrical connections discussed below.

**Wire motor to contactor**

1. See wiring schematic supplied with motor and wire motor for 240 volt operation, clockwise rotation as viewed from shaft end of motor.
2. Wire motor to motor cord which is connected to terminals 2 and 6 on the contactor thermal overload.
3. Be sure to use strain relief supplied to secure motor cord in motor junction box knock-out. Be sure green ground wire on motor cord is properly grounded to motor inside junction box. Use wire nuts and electrical tape to connect and insulate wires.

**NOTE:** Motor must run in a clockwise rotation. (Viewing top of blade, teeth must rotate from rear to front of saw.) If saw does not rotate in proper direction, wiring and all connections must be checked and corrected.

**▲ WARNING** *Once rotation is checked, disconnect power before working with motor or tool.*

**Wire magnetic starter to source**

Refer to Figure 6, page 9.

The saw should be connected to power source with permanent wiring (hard wired). Power leads are to be supplied and connected by a qualified electrician.

**IMPORTANT:** Motor and magnetic starter must be properly grounded. Wiring should be performed by a qualified electrician according to all local codes and ordinances.

1. Be certain power leads are sufficient in size to adequately carry the saw's voltage and amp load.
2. Ground the magnetic starter. Connect the ground lead to magnetic starter's ground screw. The ground lead will be green or green with yellow stripe. Fasten securely.
3. Power leads are connected to magnetic starter terminals L1 and L3.

**▲ WARNING** *Do not connect power leads to any other terminal or fastener.*

4. Wire power supply cord into junction box (Figure 11, Ref. No. 7) on rear of cabinet.

## INSTALLATION (CONTINUED)

- When wiring the saw to the source, install a fused safety disconnect switch between the saw and the circuit breaker. Be certain the safety disconnect switch is capable of being locked in the OFF position. The safety disconnect switch is a safety precaution which allows the operator to lock the saw off so it is unable to receive power. This feature is intended to prevent accidental start-up when maintaining or servicing saw. In addition, it is intended to prevent unauthorized and possible hazardous use by others.
- The safety disconnect switch is fused. Protect the saw with a 20 amp time-delay fuse or 20 amp manual reset circuit breaker. Do not use fuses or breakers with a greater amperage rating.
- Wire the saw to a breaker box or fuse box with adequate capacity wire to accommodate the stationary saw's voltage and amp load.

**IMPORTANT:** Be certain saw is wired to a circuit protected by a 20 amp breaker or fuse.

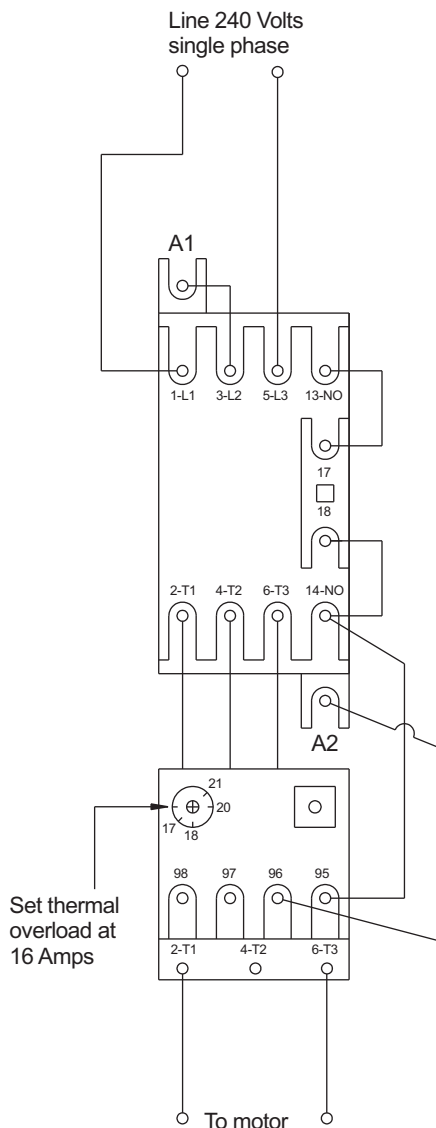

Figure 6 – Schematic

## Set thermal overload

Refer to Figure 6.

Terminal L2 is not used. Magnetic starter is protected with a thermal overload (lower right-hand corner). Be certain overload is positioned at manual (hand) reset. Position heater (overload) adjustment at saw for 16 amps. Replace cover and secure all line cords.

## Grounding instructions

**⚠ WARNING** *Improper connection of equipment grounding conductor can result in the risk of electrical shock. Equipment should be grounded while in use to protect operator from electrical shock.*

- Check with a qualified electrician if grounding instructions are not understood or if in doubt as to whether the tool is properly grounded.
- Do not remove or alter grounding prong in any manner. In the event of a malfunction or breakdown, grounding provides a path of least resistance for electrical shock.

**⚠ WARNING** *Do not permit fingers to touch the terminals of plug when installing or removing from outlet.*

- Plug must be plugged into matching outlet that is properly installed and grounded in accordance with all local codes and ordinances. Do not modify plug provided. If it will not fit in outlet, have proper outlet installed by a qualified electrician.
- Inspect tool cords periodically and if damaged, have them repaired by an authorized service facility.
- Green (or green and yellow) conductor in cord is the grounding wire. If repair or replacement of the electric cord or plug is necessary, do not connect the green (or green and yellow) wire to a live terminal.
- Many cover plate screws, water pipes and outlet boxes are not properly grounded. To ensure proper ground, grounding means must be tested by a qualified electrician.

## Extension cords

- The use of any extension cord will cause some drop in voltage and loss of power.
- Wires of the extension cord must be of sufficient size to carry the current and maintain adequate voltage.
- Use the table to determine the minimum wire size (A.W.G.) extension cord.
- Use only 3-wire extension cords having 3-prong grounding type plugs and 3-pole receptacles which accept the tool plug.
- If the extension cord is worn, cut, or damaged in any way, replace it immediately.

## INSTALLATION (CONTINUED)

### Extension cord length (230V)

Wire Size	A.W.G.
Up to 50 ft	14
50–100 ft.	12

**NOTE:** Using extension cords over 100 ft. long is not recommended.

Recommended Dayton plugs, connectors and receptacles for 240 volts:

20 Amps Plug	250 Volts Connector	NEMA L6-20 Receptacle
5A081	5A082	5A080

30 Amps Plug	250 Volts Connector	NEMA L6-30 Receptacle
5A087	5A088	5A086

## OPERATION

Refer to Figures 7 – 12.

**▲ WARNING** *For your own safety read instruction manual before operating tool:*

- Wear eye protection.
- Use saw-blade guard and spreader for every operation for which it can be used, including all through sawing.
- Keep hands out of the line of saw blade.
- Use a push-stick when required.
- Pay particular attention to instructions on reducing risks of kickback.
- Do not perform any operation freehand.
- Never reach around or over saw blade.

**▲ WARNING** *Disconnect power before attempting any of the following procedures. Be certain switch is in OFF position and safety disconnect (or breaker) is in OFF or open position. Saw blade must not be moving. Saw blade will rotate freely after motor is turned off. Allow blade to come to a complete stop before attempting any of the following procedures.*

**▲ WARNING** *The operation of any power tool can result in foreign objects being thrown into the eyes, which can result in severe eye damage. Always wear safety goggles complying with United States ANSI Z87.1 before commencing power tool operation.*

### Starting saw

**▲ WARNING** *Never operate saw without blade guards in place. Be sure blade is not in contact with workpiece when motor is started. Start motor and allow saw to come to full speed.*

**▲ WARNING** *Make sure the electrical characteristics of motor nameplate and power source are the same.*

- Saw is fitted with a safety ON/OFF switch on front left side of cabinet.
- To turn saw on, stand to either side of the blade—never in line with it. Push green START. Always allow saw blade to come up to full speed before cutting.
- Do not turn motor switch on and off rapidly. This action overheats the motor and may cause saw blade to loosen.
- Never leave saw while the power is on.
- To turn saw off, push red STOP. Never leave saw until cutting tool has come to a complete stop.

**▲ WARNING** *For your own safety, lower blade or cutting tool below table surface. If blade is tilted, return it to vertical position. Turn off safety disconnect or circuit breaker when saw is not in use.*

### Blade height adjustment

Refer to Figures 8 and 11.

- Blade height is controlled by handwheel (Figure 11, Ref. No. 27) on the front of the saw.
- To adjust height, loosen locking hand knob (Figure 11, Ref. No. 23). Rotate knob counterclockwise approximately three turns. Turn handwheel to desired blade height.

**▲ CAUTION** *For safety, blade should be raised only 1/8" above the surface of the material to be cut. However, if hollow ground blades are used, raise blade to its maximum height to allow for greater blade clearance.*

- Lock blade height into position. Lock handwheel (Figure 11, Ref. No. 27) by tightening locking hand knob (Figure 11, Ref. No. 23) clockwise. Tighten only until snug.

**IMPORTANT:** Do not over tighten. Only a small amount of pressure is necessary to lock handwheel securely.

- The blade height mechanism has two hex head bolts which function as upper and lower limit stops (Figure 8, Ref. Nos. 16 and 25). These limit stops are set at the factory and need no further adjustment.

### Blade tilt adjustment

Refer to Figures 10 and 11.

- The saw blade can be set at any angle between 90 and 45°. Blade tilt is controlled by the handwheel (Figure 11, Ref. No. 27) on the left side of the saw. The indicator (Figure 10, Ref. No. 15) on front of saw shows the tilt angle of the blade.
- To adjust tilt, loosen locking hand knob (Figure 11, Ref. No. 23). Rotate knob counterclockwise at least three turns. Turn handwheel to desired blade angle. Lock blade angle into position.
- Lock handwheel (Figure 11, Ref. No. 27) by tightening locking hand knob (Figure 11, Ref. No. 23) clockwise. Tighten only until snug.

## OPERATION (CONTINUED)

- The saw is equipped with positive stops at 90 and 45°. These positive stops allow operator to position saw blade at 90 and 45° quickly and accurately.

### **90° Stop adjustment**

Refer to Figure 10.

- Raise saw blade above table as far as possible. Set blade at 90° to table by turning the tilting handwheel. Place a square on table and check to see if blade is perpendicular to the table. When checking put square flush against saw blade. Do not put square on teeth of saw blade.
- If 90° adjustment is necessary, loosen hex nut (Ref. No. 19) on hex head bolt (Ref. No. 21) and turn hex head bolt.
- Using the square, rotate the tilting handwheel until blade is 90° to table. When exactly at 90°, turn hex head bolt (Ref. No. 21) against the lug on the front trunnion. Do not turn too far; recheck 90°. Tighten hex nut securely.
- Check tilt indicator (Ref. No. 15). If necessary, adjust pointer so it points to 0° mark on scale. To adjust pointer, remove handwheel and loosen screw (Ref. No. 13). Be sure to tighten screw securely after adjustment is completed.

### **45° Stop adjustment**

Refer to Figure 10.

- Tilt the saw blade to 45°. Using a combination square, check to see if blade is 45° to the table.
- If 45° adjustment is necessary, adjust 45° stop in the same manner as the 90° stop. The only exception is that hex head bolt and hex nut (Ref. Nos. 21 and 19) are on the other end of the rack. Adjust the indicator if necessary.

### **Miter gauge adjustment**

- Miter gauge supplied with saw is equipped with individually adjustable index stops at 90 and 45°, right and left.  
Adjustment to index stops can be made by loosening hex nut and tightening or loosening three pan head screws. Be sure to tighten hex nut after adjustment is made.
- Face of miter gauge has two holes for purpose of attaching auxiliary facing.
- Miter gauge is accurately constructed for precision work. Miter gauge is guided through T-slot with a roller guide mounted at front of guide bar. Roller guide adds to miter gauge stability and prevents the guide bar from leaving T-slot.
- To operate miter gauge, simply loosen lock handle and move miter gauge to desired angle. The miter gauge will stop at 90 and 45°, both right and left. To position miter gauge past these points, simply push down gauge stop. Position miter gauge at desired angle and tighten lock handle.
- Be positive the edge of workpiece next to face of miter gauge is straight and tight against miter gauge so that the workpiece

does not rock or rotate. Always use both hands when operating the miter gauge.

- The miter gauge is used for cross-cutting, compound miter cutting, miter cutting, rabbeting, bevel cutting and dadoing.

### **Rip fence adjustment**

The saw's rip fence is precision manufactured, incorporating fine adjustments for accurate cuts. The saw is built to allow the operator to accurately adjust the rip fence without problems in a matter of seconds. The saw uses a unique system of T-blocks. These T-blocks, when correctly placed, give the operator an immediate index to properly adjust and set the rip fence into position.

### **Align rip fence parallel with blade and miter gauge slots**

Refer to Figure 11.

- The rip fence is aligned using both T-blocks in either miter gauge slot. Secure both T-blocks (Ref. No. 31) to one slot (front and rear on table) with socket head bolts (Ref. No. 30). Position the T-blocks on the table so the T is in the slot and the entire block is on the table and not hanging over an edge. These blocks are now the index (stops) used to align the rip fence.
- Unlock rip fence and position it against T-blocks. While against blocks, place the locking lever in down position locking fence in place. The rip fence is aligned when it is flush against both T-blocks. Adjust rip fence if necessary.

### **Adjust rip fence**

Refer to Figure 12.

**NOTE:** When adjusting the fence (Ref. No. 8), always adjust T-blocks to the face of the fence which the workpiece contacts. T-blocks should always be between blade and fence.

- Unlock rip fence and adjust using set screws (Ref. No. 11) so that fence will be flush with both T-blocks. Lock rip fence against T-blocks with lever (Ref. No. 14).
- Rip fence should now be aligned with both T-blocks. If rip fence is not aligned, unlock fence and repeat adjustment. Remove T-blocks.
- Occasionally, after aligning rip fence with T-blocks, check to see if rip fence is aligned with blade. If rip fence is in alignment with T-blocks and is not in alignment with blade, table is not parallel with blade. To adjust table see Assembly, page 5, "Check table alignment."
- Calibrating the scale can now be completed. The rip fence scale is located on the guide rail (Ref. No. 2). The scale is used to measure the distance between the right side of the blade and rip fence. The scale is viewed through the lens (Ref. No. 20) on the guide casting.

## OPERATION (CONTINUED)

- Raise blade as far as possible. Gently move the rip fence against the right side of the blade. In this position the indicator should read zero. If not, lock the fence in place with lever (Ref. No. 14). Loosen screws (Ref. No. 23) and position lens bracket (Ref. No. 21) so that indicator reads zero and retighten screws.
- The height of the rip fence can be adjusted by the plastic screws (Ref. No. 19).
- Check to be certain rip fence is aligned with blade and indicator reads zero. If not, repeat adjustment steps.

### Rip fence operation

Refer to Figure 12.

- Unlock the fence by lifting the locking lever (Ref. No.14). Using the scale for placement, position the rip fence. Lock the rip fence into position by placing the locking lever in the down position.
- The rip fence is used for the following operations: ripping, bevel ripping, ploughing, resawing, rabbeting and dadoing.

**▲ WARNING** *For your own safety, always observe the following safety precautions.*

- Never make any cut freehand (without using miter gauge or rip fence). Blade can bind in the cut and cause a kickback.
- Always lock miter gauge or rip fence securely when in use.
- Remove rip fence from the table when miter gauge is in use.
- Remove miter gauge from table when rip fence is in use.
- Make sure blade guard is installed for all “through-sawing” operations. Replace guard immediately after completion of resawing, rabbeting and dadoing.

Frequently check action of anti-kickback pawls by passing the workpiece alongside the spreader while saw is off. Pull the workpiece toward you. If the pawls do not dig into the workpiece and hold it, the pawls must be sharpened. (See Maintenance section, page 14.)

- Have blade extend approximately 1/8” above top of workpiece. Additional blade exposure increases hazard potential.
- Do not stand directly in front of blade in case of a kickback. Stand to either side of the blade.
- Keep your hands clear of the blade and out of the path of the blade.
- If the blade stalls or stops while cutting, turn switch OFF and safety disconnect OFF before attempting to free the blade.
- Do not reach over or behind the blade to pull the workpiece through the cut, to support long or heavy workpieces, to remove small cut-off pieces of material or for any other reason.
- Do not pick up small pieces of cut-off material from the table. Remove them by pushing them off table with a long stick. Otherwise they could be thrown back at you by the rear of the blade.
- Do not remove small pieces of cut-off material that may become trapped inside blade guard while saw is on. This could

endanger your hands or cause a kickback. Turn saw off. After blade has stopped turning, lift guard and remove the piece.

- Always lower blade below the table level when machine is not in use.

### Through cuts

A through cut is a sawing operation in which the workpiece is completely sawn through. Examples of through cuts are rip cuts, cross cuts, miter cuts and beveled cuts. The blade guard assembly MUST be used when performing through cuts.

### Crosscutting

**▲ WARNING** *Use caution when starting the cut to prevent binding of the guard against the workpiece.*

This cut is performed with the miter gauge set at “0”. Crosscutting is used for cutting across the workpiece grain at 90° (blade square with both the edge and the flat side of the wood).

### Miter cutting

**▲ WARNING** *Miter angles greater than 45° may force the blade guard assembly into the saw blade causing damage to the blade guard assembly and personal injury. Before starting the motor, test the operation by feeding the workpiece into the blade guard assembly. If the blade guard assembly contacts the blade, place the workpiece under the blade guard assembly, not touching the blade, before starting the motor.*

**▲ WARNING** *Certain workpiece shapes, such as molding may not lift the blade guard assembly properly. With the power off, feed the workpiece slowly into the blade guard area and until the workpiece touches the blade. If the blade guard assembly contacts the blade, place the workpiece under the blade guard assembly, not touching the blade, before starting the motor.*

This cut is performed with the miter gauge, and is used for cutting at an angle other than 90° square with the edge of the workpiece.

### Bevel crosscutting

**▲ WARNING** *When possible, use the right miter gauge slot when bevel crosscutting so that the blade tilts away from the miter gauge and your hands.*

**▲ WARNING** *Use caution when starting the cut to prevent binding of the guard against the workpiece.*

This cut is performed with the miter gauge, and is the same as crosscutting, except that the workpiece is also cut at an angle other than 90° square to the flat side of the wood (blade is at an angle).

### Compound miter cutting

This cut is performed with the miter gauge, and is a combination of miter cutting and bevel crosscutting. Cut is made at angle other than 90° to both the edge and flat side of wood.

## OPERATION (CONTINUED)

### Ripping

**▲ WARNING** *When bevel ripping and whenever possible, place the fence on the side of the blade so that the blade is tilted away from the fence and hands. Keep hands clear of the blade and use a push stick to feed the workpiece if there is less than 6" between the fence and the blade.*

This cut is performed with the rip fence, and is used to cut the workpiece lengthwise with the grain. Position the fence to the desired width of rip and lock in place. When ripping long boards or large panels always use a work support.

### Bevel ripping

**▲ WARNING** *Before connecting the table saw to the power source or operating the saw, always inspect the blade guard assembly and riving knife for proper alignment and clearance with saw blade. Check alignment after each change of bevel angle.*

**▲ WARNING** *When possible, place the fence on the right side of the blade so that the blade is tilted away from the fence and hands. Keep your hands clear of the blade and use a pushstick to feed the workpiece if there is less than 6" between the fence and the blade.*

This cut is performed with the rip fence, and is the same as ripping, except that the blade is set at an angle other than 90°.

### Resawing

Performed with rip fence, is known as ripping a piece of wood through its thickness. Do not attempt to resaw bowed or warped material.

**NOTE:** It may be necessary to remove blade guard and use work supports as well as push blocks when performing this operation.

**▲ WARNING** *Install blade guard immediately upon completion of resawing operation.*

### Ploughing

Performed with rip fence, is grooving with grain long way of workpiece. Use proper hold downs and feed devices.

### Rabbeting

Performed with either miter gauge or rip fence. Rabbeting is known as cutting out a section of the corner of a piece of material, across an end or along an edge. To make a rabbet requires cuts which do not go all the way through the material. Therefore, blade guard must be removed. Install blade guard immediately upon completion of rabbeting operation. Rabbet cuts can also be made using dado head.

### Dadoing

Performed with either miter gauge or rip fence. Dadoing is done with a set of blades (dado set) rather than standard 10 or 12" saw blades. The dado set is used to groove wood similar to ploughing and rabbeting. However, the dado set allows operator to remove more material in one pass. The operator, with a dado set, can vary width of cut up to 13/16".

Instructions for operating dado set are contained in owner's manual furnished with dado set. Dadoing requires cuts which do not go all the way through material. Therefore, blade guard must be removed. Dado sets have different characteristics than saw blades. As a result, saw must be fitted with special parts that are furnished with saw.

Dayton stationary saw dado set maximum capacity is 5/8 I.D. x 8 O.D. x 13/16" width.

When using a dado set, the following parts must be substituted (See Figure 9): 5/8" dado arbor extension (Ref. No. 36) and dado table insert (Figure 11, Ref. No. 6). (See Assembly.)

**IMPORTANT:** Always use correct insert. When using the dado set, use caution. Use featherboards and push sticks as applicable.

**▲ WARNING** *Always immediately replace the standard blade arbor, standard blade, blade guard and blade insert when you are finished dadoing.*

### Cutting oversized workpieces

When cutting long workpieces or large panels, always support workpiece that is not on table. Use adjustable roller stand or make simple support by clamping a piece of plywood to saw horse. Add facings to miter gauge or rip fence as needed.

**IMPORTANT:** Do not allow facings to interfere with operation of blade guard.

### Dust collecting

1. Saw is fitted with a 4" male exhaust port. When a dust collector is used, cover louvers on door. This will create a better vacuum within cabinet and result in more efficient sawdust removal. It is recommended to tape louvers closed or seal with a sheet of plastic.

**IMPORTANT:** If dust collector is NOT used when saw is running, be sure louvers are open (for good air circulation to keep motor from overheating).

2. Before starting saw, see that all adjustments are properly made and guards in place. With power disconnected, turn pulley by hand to make sure everything is correct before connecting power and starting saw.

## OPERATIONS (CONTINUED)

### Blade selection

Blade selection is based on type of material being cut and how it will be cut. There are three general types of saw blades: rip saw blades cut with grain of wood, cut-off saw blades cut across grain, and combination saw blades cut with grain, across grain and any angle to grain.

Blades vary in many aspects. When selecting a blade, the following blade characteristics should match up with operation to be performed and type of material to be cut: type of steel; quality of steel; tooth style; tooth set; carbide tipped; grind; number of teeth and size.

**IMPORTANT:** Your saw is only as accurate and efficient as blade or cutting tool used.

First, be certain to use the appropriate type of cutting tool for the operation to be performed. Second, it is strongly recommended that high-quality blades and cutting tools be used. Be certain blades and cutting tools are kept sharp and in good working order. Check blades periodically and replace or sharpen if necessary.

## MAINTENANCE

**⚠ WARNING** *Do not attempt under any circumstances, to service, repair, dismantle, or disassemble any mechanical or electrical components without physically disconnecting all power sources.*

### Cleaning

Clean off any preservative on bright (machined) parts with appropriate solvent (mineral spirits). Avoid getting cleaning fluid on any rubber parts as they tend to deteriorate rubber. Use soap and soft water on rubber and plastic parts.

After cleaning, lubricate unpainted surfaces with a light application of medium consistency machine oil. This lubrication should be repeated at least once every six months.

**NOTE:** Instead of oil, a good quality paste wax can be applied to rip fence and table surface. Paste wax will enhance movement of workpieces. In addition to providing lubrication, paste wax will help prevent rusting.

Keep your machine and your workshop clean. Do not allow sawdust to accumulate on saw or inside cabinet.

Frequently vacuum or blow out any sawdust that may accumulate within cabinet. Be certain motor and internal mechanisms are clean and are frequently vacuumed or blown free of any dirt. For motor maintenance, follow instructions provided with motor.

### Lubrication

All bearings on the arbor are shielded ball bearings. These bearings are permanently lubricated at the factory.

As needed, clean the grease off the rack and worm gears of height and tilt mechanism. Lubricate rack and gears with a medium viscosity machine oil.

Be sure to lubricate trunnion ways and all bushings.

Occasionally oil all other bearing points, including blade guard assembly, miter gauge and rip fence.

For motor lubrication, follow instructions provided with the motor.

### Service

Replace belts and worn parts as needed. If power cords are worn, cut, or damaged in any way, have them replaced immediately.

Make sure teeth of anti-kickback pawls are always sharp.

Sharpen dull teeth using a few light strokes of a smooth cut flat file.

Service motor according to the instructions provided. The motor should be serviced only by a qualified electrician.

### Changing the blade

See "Blade Installation", page 5.



## TROUBLESHOOTING GUIDE

Symptom	Possible Cause(s)	Corrective Action
Saw stops or will not start	1. Overload tripped	1. Allow motor to cool and reset by pushing reset switch
	2. Saw unplugged from wall or motor	2. Check all plug connections
	3. Fuse blown or circuit breaker tripped	3. Replace fuse or reset circuit breaker
	4. Cord damaged	4. Replace cord
	5. Defective capacitor	5. Replace capacitor
Excessive vibration	1. Stand on uneven floor	1. Reposition on flat, level surface
	2. Damaged saw blade	2. Replace saw blade
	3. Bad drive V-belts	3. Replace drive V-belts
	4. Bent pulley	4. Replace pulley
	5. Improper motor mounting	5. Check and adjust motor
	6. Loose hardware	6. Tighten hardware
	7. Loose set screw in pulley	7. Tighten set screw
Cannot make square cut when crosscutting	Miter gauge not adjusted properly	Adjust miter gauge
Blade stalls (however, motor turns)	1. Drive belts not tight	1. Adjust drive belt tension. Refer to Figure 8, page 20. Loosen bolt (Ref. No. 11), push motor down with pry bar and tighten bolt to secure motor position.
	2. Drive belts worn	2. Replace drive belts
Blade does not come up to speed	1. Extension cord too light or too long	1. Replace with adequate size cord
	2. Low shop voltage	2. Contact your local electric company
	3. Motor not wired for correct voltage	3. Refer to motor junction box
Cut binds, burns or stalls when ripping	1. Dull blade with improper tooth set	1. Sharpen or replace blade
	2. Blade is binding at one end of cut (heeling)	2. Adjust table and rip fence parallel to blade
	3. Warped board	3. Make sure concave or hollow side is facing down; feed slowly
	4. Rip fence not parallel to blade	4. Adjust rip fence
	5. Riving knife out of alignment	5. Adjust riving knife to fall in line with blade
	6. Excessive feed rate	6. Reduce feed rate
Cut not true at 45 or 90° positions	Positive stops not properly adjusted	Adjust blade tilt
Tilt and elevating handwheel difficult to turn	1. Sawdust on rack and worm gears	1. Clean and relubricate
	2. Bushings and bearing surfaces dirty	2. Clean thoroughly and lubricate
Rip fence binds on guide tube	1. Guide rails or extension wing not properly installed	1. Reassemble guide rails
	2. Guide of rip fence not adjusted properly	2. Adjust guides
Frequent opening of fuses or circuit breakers	1. Motor overloaded	1. Feed work slower into blade
	2. Fuses or circuit breakers do not have sufficient capacity	2. Install proper size fuses or circuit breakers
Material kicked back from blade	1. Rip fence out of alignment	1. Align rip fence with miter slot
	2. Riving knife not aligned with blade	2. Align riving knife with blade
	3. Feeding stock without rip fence	3. Always use rip fence or miter gauge
	4. Riving knife not in place	4. Install riving knife
	5. Dull blade	5. Replace blade
	6. Letting go of material before it is past blade	6. Push material all the way past blade before releasing work
	7. Anti-kickback fingers dull	7. Replace or sharpen anti-kickback fingers
Saw makes unsatisfactory cut	1. Dull blade	1. Sharpen or replace blade
	2. Blade mounted backwards	2. Turn blade around
	3. Gum or pitch on blade	3. Remove blade and clean
	4. Incorrect blade for cut	4. Change blade to correct type
	5. Gum or pitch on table	5. Clean table



**REPAIR PARTS ILLUSTRATION FOR BLADE GUARD**

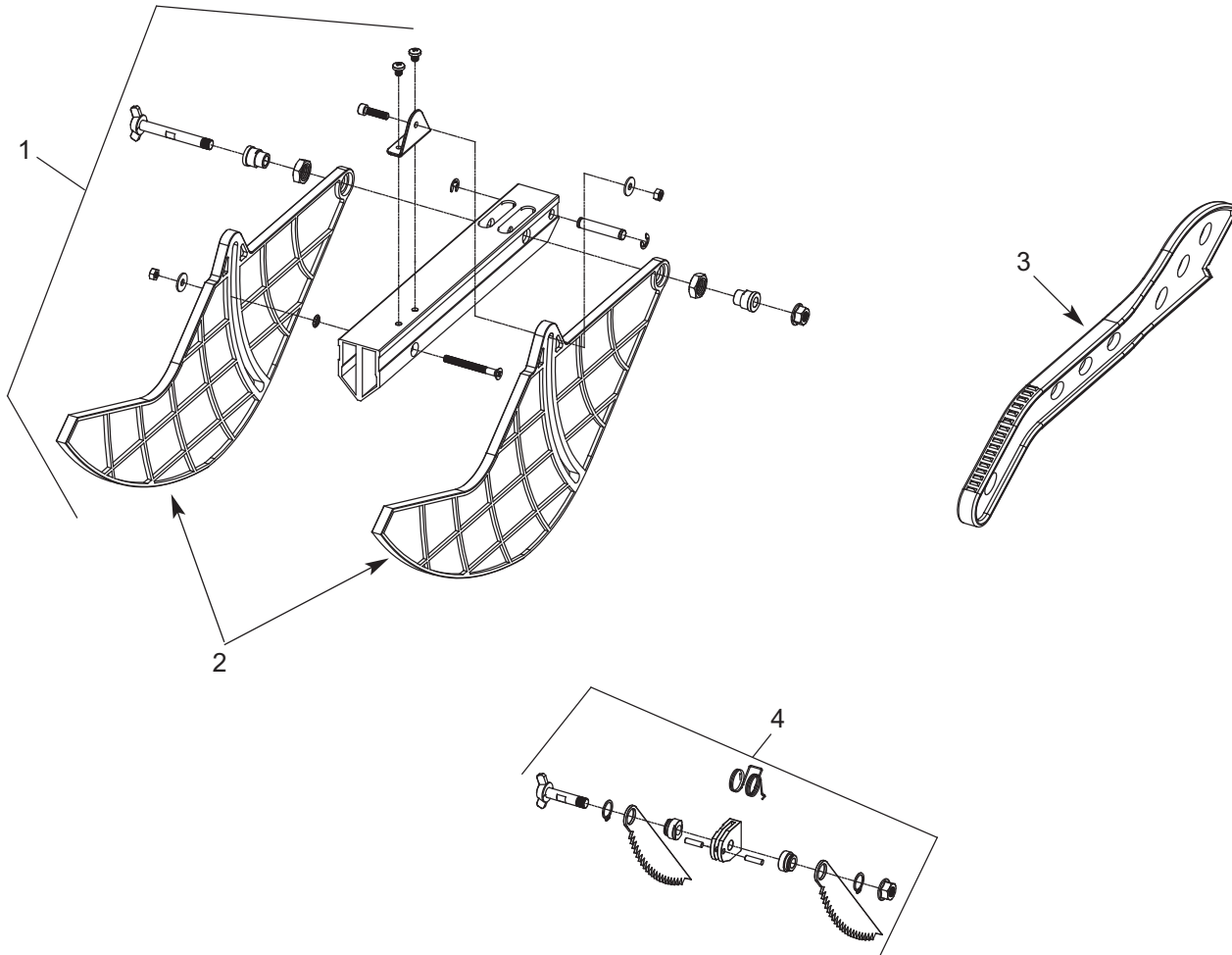

**Figure 7 – Repair Parts Illustration for Blade Guard**

**REPAIR PARTS LIST FOR BLADE GUARD**

Ref. No.	Description	Part No.	Qty.
1	Blade guard assembly	32235.00	1
2	Set of blade guards	32236.00	1
3	Push stick	32237.00	1
4	Pawl set assembly	32238.00	1

(Δ) Not shown.

(\*) Standard hardware item, available locally.

(N/A) Not available as replacement part.

**For Repair Parts, call 1-800-Grainger**  
**24 hours a day – 365 days a year**

Please provide following information:

-Model number

-Serial number (if any)

-Part description and number as shown in parts list

**REPAIR PARTS ILLUSTRATION FOR MOTOR**

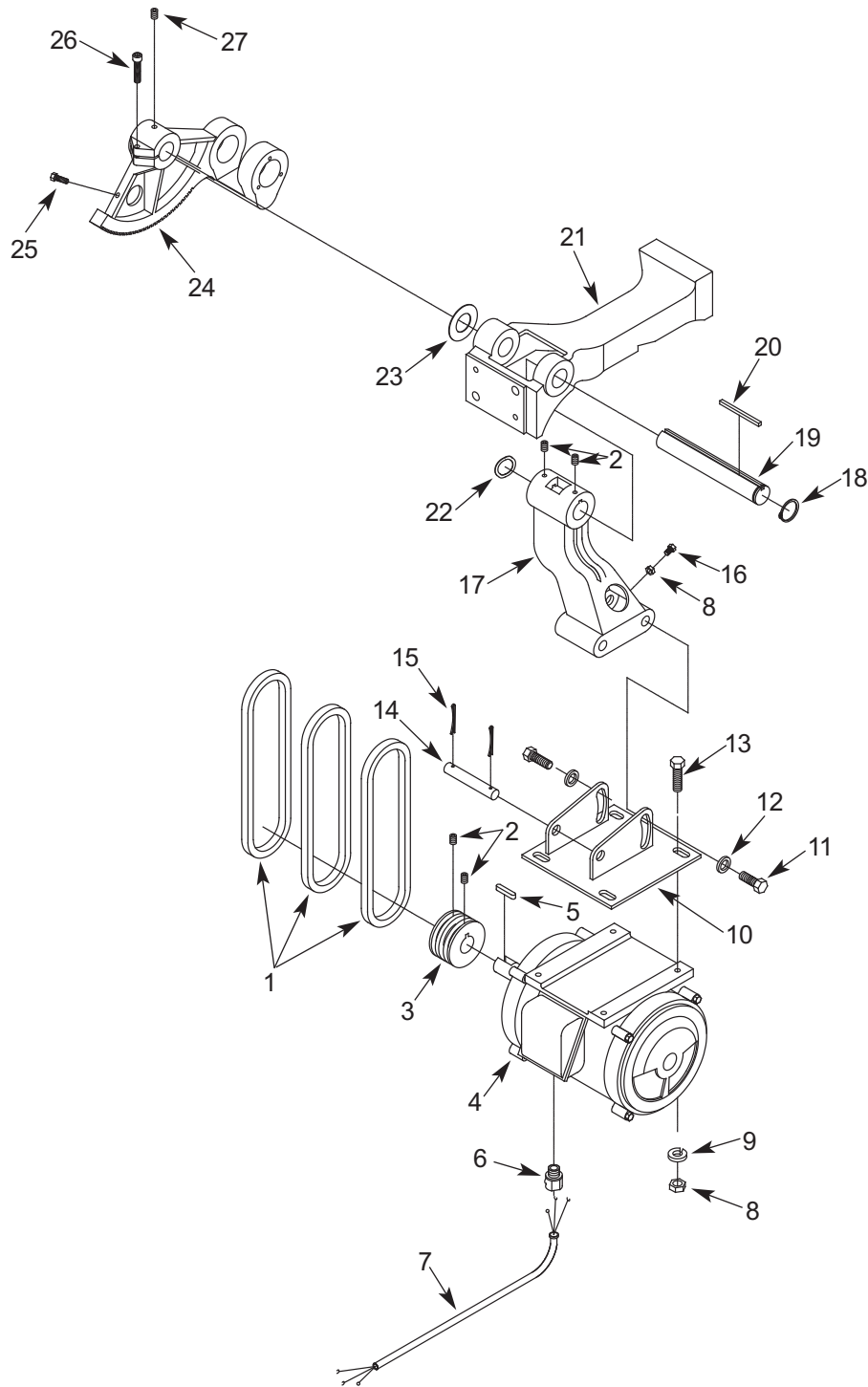

**Figure 8 – Repair Parts Illustration for Motor**

**For Repair Parts, call 1-800-Grainger**  
**24 hours a day – 365 days a year**

*Please provide following information:*

- Model number
- Serial number (if any)
- Part description and number as shown in parts list

## REPAIR PARTS LIST FOR MOTOR

Ref. No.	Description	Part No.	Qty.
1	V-Belt	23057.00	3
2	6-1.0 x 6mm Set screw	*	4
3	Motor pulley	15095.00	1
4	Motor with key	15094.00	1
5	Key	15096.00	1
6	Strain relief	23158.00	1
7	Line cord	23159.00	1
8	8-1.25mm Hex nut	*	5
9	8mm Lock washer	*	4
10	Motor mount plate	23160.00	1
11	12-1.75 x 15mm Hex head bolt	*	2
12	12mm Flat washer	*	2
13	8-1.25 x 25mm Hex head bolt	*	4
14	Pivot shaft	23161.00	1
15	Cotter pin	00983.00	2
16	8-1.25 x 35mm Hex head bolt	*	1
17	Motor mount support	08455.00	1
18	3AMI-28 Retaining ring	01022.00	1
19	Shaft	01012.00	1
20	5 x 5 x 75mm Key	01011.00	1
21	Arm	08454.00	1
22	30mm Wavy washer	08456.00	1
23	Brass washer	00976.00	1
24	Arbor bracket	00959.00	1
25	6-1.0 x 12mm Hex head bolt	*	1
26	8-1.25 x 25mm Socket head bolt	*	1
27	8-1.25 x 12mm Cone point set screw	08457.00	1

(Δ) Not shown.

(\*) Standard hardware item, available locally.

(N/A) Not available as replacement part.

20 REPAIR PARTS ILLUSTRATION FOR ARBOR AND RIVING KNIFE

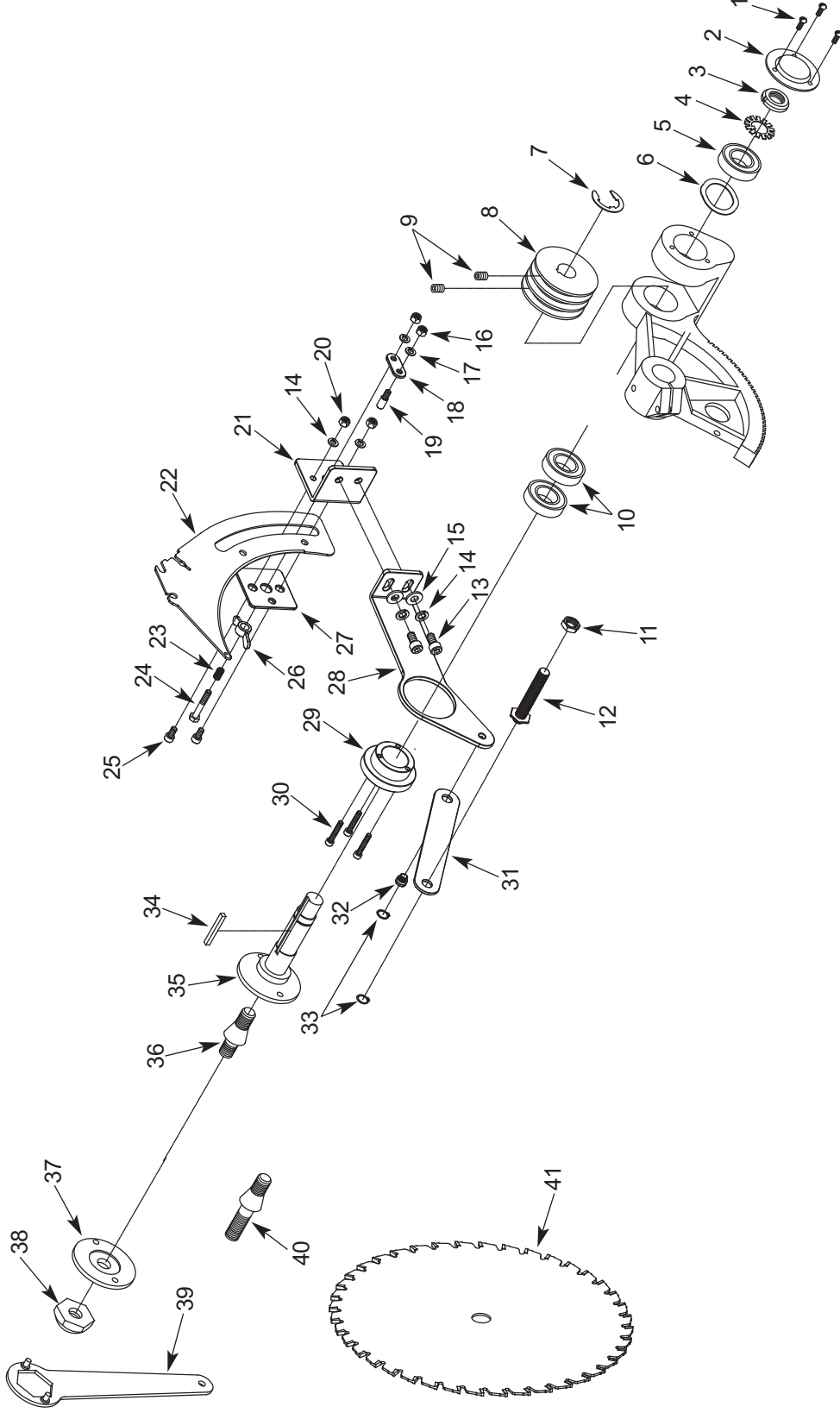

Figure 9 – Repair Parts Illustration for Arbor and Riving Knife

**For Repair Parts, call 1-800-Granger**

**24 hours a day – 365 days a year**

Please provide following information:

- Model number
- Serial number (if any)
- Part description and number as shown in parts list

## REPAIR PARTS LIST FOR ARBOR AND RIVING KNIFE

Ref. No.	Description	Part No.	Qty.
1	5-0.8 x 8mm Pan head screw	*	3
2	Bearing cover	00992.00	1
3	20mm Locking nut	00991.00	1
4	Keyed washer	00990.00	1
5	6204Z Bearing	00235.00	1
6	35mm Wavy washer	00988.00	1
7	3CMI-22 E-ring	00987.00	1
8	Drive pulley	00986.00	1
9	6-1.0 x 6mm Set screw	*	2
10	6005Z Bearing	17736.00	2
11	12-1.75mm Hex nut	*	1
12	Connecting bolt	32215.00	1
13	8-1.25 x 16mm Socket head bolt	*	2
14	8mm Lock washer	*	4
15	8mm Flat washer	*	2
16	5-0.8mm Hex nut	*	2
17	5mm Lock washer	*	2
18	Push plate	32218.00	1
19	Position plate	32219.00	1
20	8-1.25mm Hex nut	*	2
21	Depth bracket	32220.00	1

(Δ) Not shown.

(\*) Standard hardware item, available locally.

(N/A) Not available as replacement part.

Ref. No.	Description	Part No.	Qty.
22	Riving knife	32222.00	1
23	Spring	32227.00	1
24	Push bolt	32228.00	1
25	Guide pin	32229.00	2
26	Lock nut	32226.00	1
27	Washer	32224.00	1
28	Riving knife support	32216.00	1
29	Ring	32230.00	1
30	5-0.8 x 20mm Socket head bolt	*	3
31	Connecting plate	32214.00	1
32	Roll pin	32213.00	1
33	3AMI-8 Retaining ring	05148.00	2
34	5 x 5 x 45mm Key	00984.00	1
35	Arbor	23163.00	1
36	Arbor extension 5/8" O.D.	23164.00	1
37	Blade flange 5/8" I.D.	01030.00	1
38	Arbor nut 5/8" I.D.	01029.00	1
39	Spanner wrench	01032.00	1
40	10" Dado extension 5/8" O.D.	23162.00	1
41	10" x 5/8" x 40T Blade	32244.00	1

22 REPAIR PARTS ILLUSTRATION FOR TILT MECHANISM

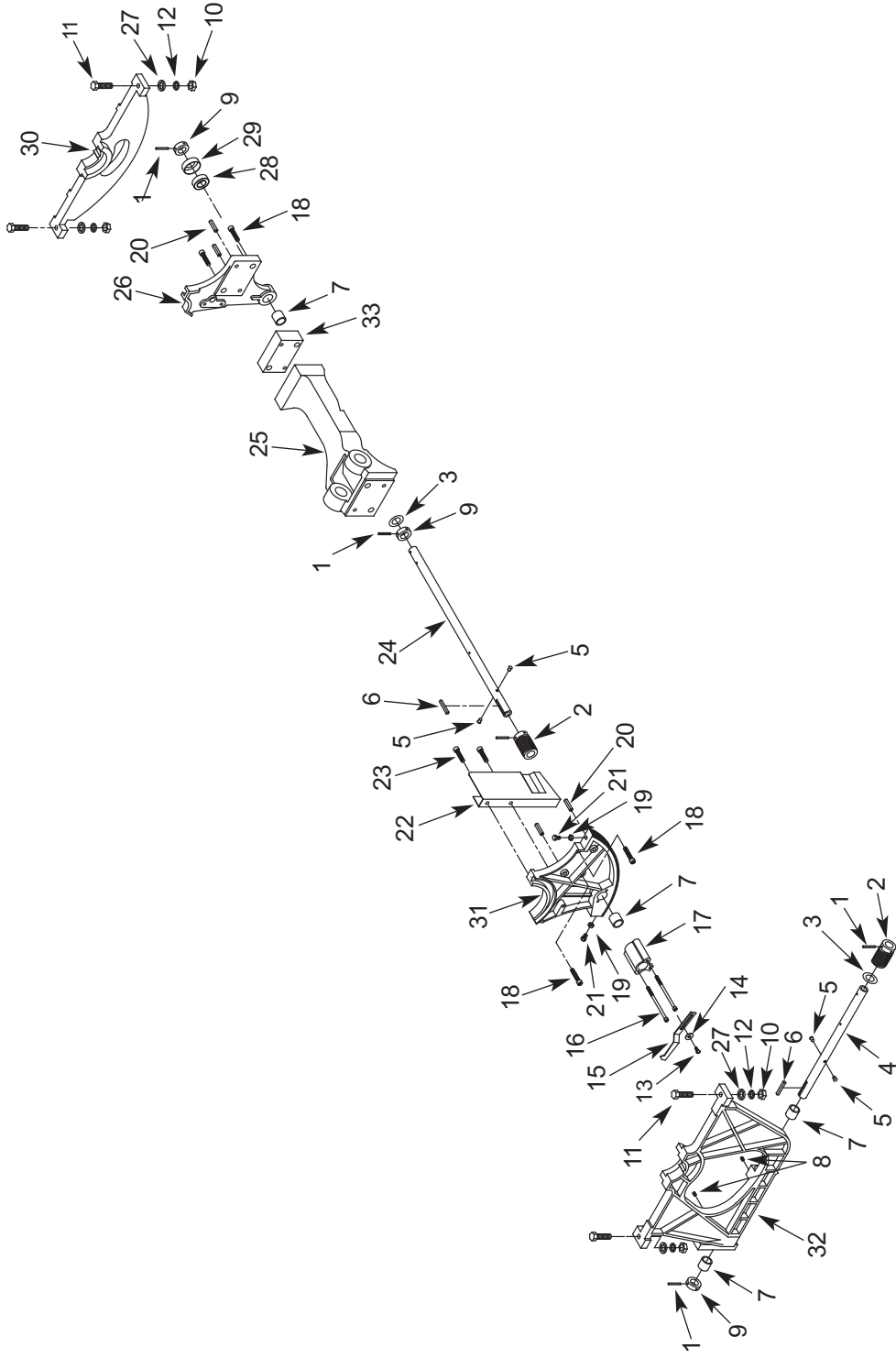

Figure 10 – Repair Parts Illustration for Tilt Mechanism

**For Repair Parts, call 1-800-Granger**

**24 hours a day – 365 days a year**

Please provide following information:

- Model number
- Serial number (if any)
- Part description and number as shown in parts list



## REPAIR PARTS LIST FOR TILT MECHANISM

Ref. No.	Description	Part No.	Qty.	Ref. No.	Description	Part No.	Qty.
1	4 x 10mm Spring pin	00971.00	5	18	10-1.5 x 55mm Socket head bolt	02592.00	2
2	Worm gear	01014.00	2	19	8-1.25mm Hex nut	*	2
3	19mm I.D. Brass washer	00950.00	2	20	8 x 75mm Roll pin	32407.00	2
4	Tilt adjustment shaft	08449.00	1	21	8-1.25 x 35mm Hex head bolt	*	2
5	Limit stud	00972.00	4	22	Dust deflector	08452.00	1
6	5 x 5 x 25mm Key	00975.00	2	23	6-1.0 x 12mm Socket head bolt	*	2
7	Bushing	00951.00	4	24	Height adjustment shaft	08453.00	1
8	6-1.0 x 6mm Set screw	*	2	25	Arm	08454.00	1
9	Collar	00970.00	3	26	Rear trunnion	01004.00	1
10	10-1.5mm Hex nut	*	4	27	10mm Flat washer	*	4
11	10-1.5 x 35mm Hex head bolt	*	4	28	51104 Bearing	01020.00	1
12	10mm Lock washer	*	4	29	Bearing dust deflector	01019.00	1
13	5-0.8 x 8mm Pan head screw	*	1	30	Rear trunnion bracket	01023.00	1
14	5mm Flat washer	*	1	31	Front trunnion	00977.00	1
15	Indicator	00967.00	1	32	Front trunnion bracket	17512.00	1
16	5-0.8 x 75mm Socket head bolt	00966.00	2	33	Adapter	32446.00	1
17	Indicator bracket	08450.00	1				

(Δ) Not shown.

(\*) Standard hardware item, available locally.

(N/A) Not available as replacement part.



## REPAIR PARTS LIST FOR TABLE AND BASE

Ref. No.	Description	Part No.	Qty.
1	Table	32374.00	1
2	Extension table	23168.00	2
3	10-1.5 x 35mm Hex head bolt	*	6
4	10mm Lock washer	*	10
5	Blade insert assembly	32376.00	1
6	Dado insert assembly	32378.00	1
7	Junction box assembly	32242.00	1
8	Handwheel support	01065.00	1
9	8-1.25 x 20mm Socket head bolt	*	2
10	10-1.5 x 30mm Hex head bolt	*	4
11	Base	NA	1
12	Door	32380.00	1
13	Crank handle	01061.00	2
14	Contact switch box with contactor	23152.00	1
15	Strain relief	01628.00	3
16	5-0.8 x 15mm Pan head screw	*	2
17	Power cord	32410.00	1
18	Cord clamp	00131.00	2
19	5-0.8mm Hex nut	*	2
20	Line cord	23171.00	1
21	3/8-16 x 31/2" Pan head screw	*	2
22	3/8"-16 Hex nut	*	2
23	Locking knob	01059.00	2
24	5-0.8 x 8mm Pan head screw	*	6
25	5mm Flat washer	*	2
26	Scale	01046.00	1
27	Handwheel	01063.00	2
28	6-1.0 x 6mm Set screw	*	2
29	10mm Flat washer	*	6
30	6-1.0 x 20mm Socket head bolt	*	2
31	T-block	01041.00	2
32	Strain relief	01634.00	1
33	5mm Serrated washer	01474.00	2
34	5-0.8 x 8mm Pan head screw	*	2

(Δ) Not shown.

(\*) Standard hardware item, available locally.

(N/A) Not available as replacement part.

**REPAIR PARTS ILLUSTRATION FOR RIP FENCE**

GETTING STARTED

SAFETY / SPECIFICATIONS

ASSEMBLY / INSTALLATION

OPERATION

TROUBLESHOOTING

MAINTENANCE / REPAIR

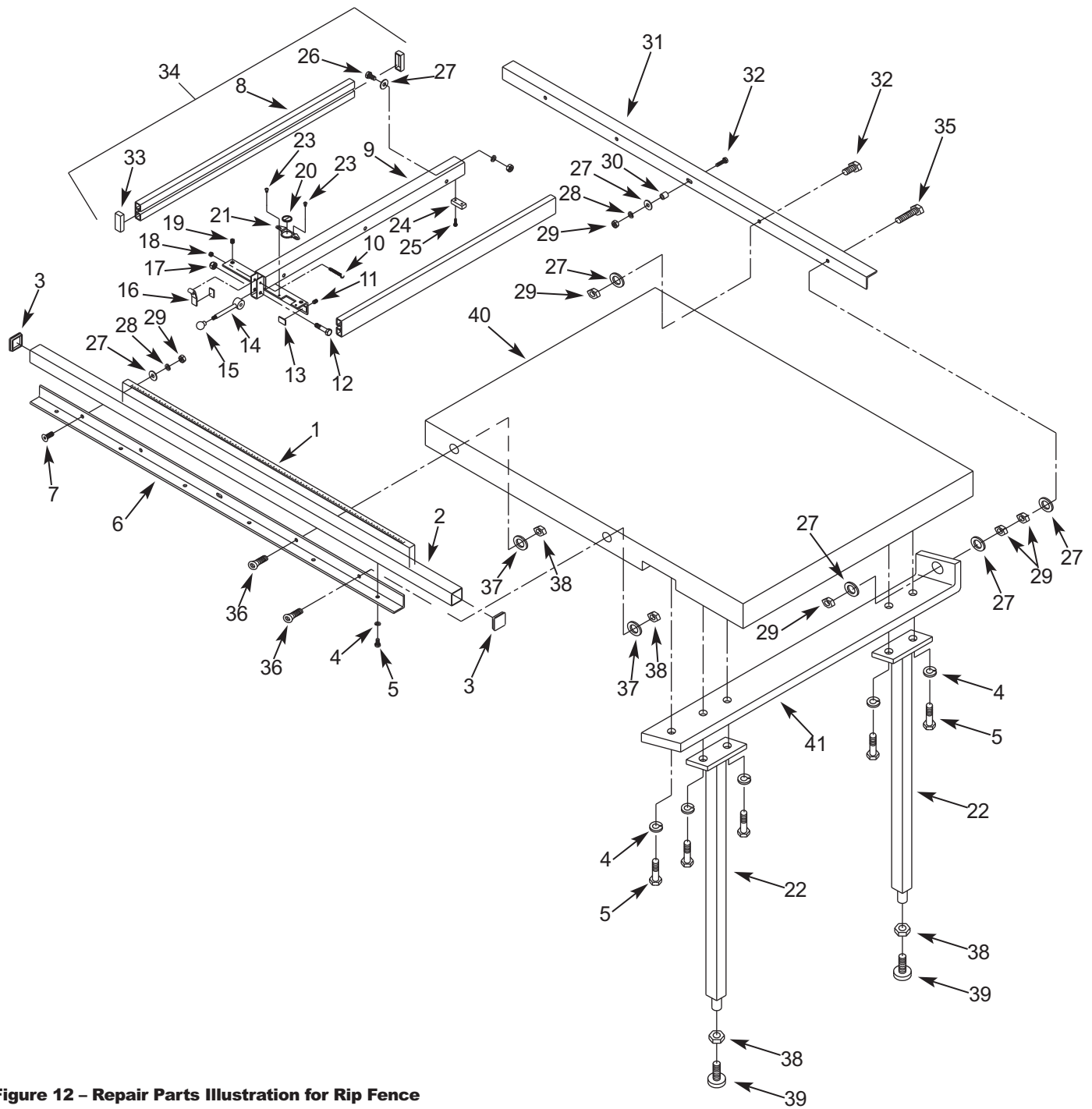

**Figure 12 - Repair Parts Illustration for Rip Fence**

**For Repair Parts, call 1-800-Grainger**

**24 hours a day - 365 days a year**

Please provide following information:

- Model number
- Serial number (if any)
- Part description and number as shown in parts list

## REPAIR PARTS LIST FOR RIP FENCE

Ref. No.	Description	Part No.	Qty.
1	Scale	15940.00	1
2	Guide rail	15941.00	1
3	Rail cover	15943.00	2
4	8mm Lock washer	*	11
5	8-1.25 x 16mm Hex head bolt	*	11
6	Front rail	15944.00	1
7	10-1.5 x 30mm Flat head screw	*	3
8	Fence	29312.00	2
9	Body	29313.00	1
10	6-1.0 x 45mm Hex head bolt	*	1
11	8-1.25 x 12mm Set screw	*	2
12	3/8-16 x 13/4" Hex head bolt	*	1
13	Pad	15950.00	3
14	Lever	15951.00	1
15	Knob	15952.00	1
16	Clamp shoe	15953.00	1
17	3/8"-16 Fiber hex nut	*	1
18	6-1.0mm Fiber hex nut	*	1
19	Plastic screw	15954.00	2
20	Lens	15955.00	1
21	Lens bracket	15956.00	1
22	Leg	23126.00	2
23	5-0.8 x 8mm Flat head screw	*	3
24	Plastic pad	15957.00	1
25	5-0.8 x 15mm Hex head bolt	*	2
26	10-1.5 x 20mm Hex head bolt	*	6
27	10mm Flat washer	*	16
28	10mm Lock washer	*	12
29	10-1.5mm Hex nut	*	16
30	Spacer	15959.00	3
31	Rear rail	15092.00	1
32	10-1.5 x 35mm Hex head bolt	*	4
33	Fence cover	29314.00	4
34	Rip fence assembly (includes Ref. Nos. 8-29)	15099.00	1
35	10-1.5 x 70mm Hex head bolt	*	1
36	8-1.25 x 35mm Flat head screw	22060.00	2
37	8mm Flat washer	*	2
38	8-1.25mm Hex nut	*	4
39	Foot	23121.00	2
40	Extension table	23122.00	1
41	Support bar	23124.00	1
Δ	Miter gauge assembly	32411.00	1

(Δ) Not shown.

(\*) Standard hardware item, available locally.

(N/A) Not available as replacement part.





## **DAYTON ONE-YEAR LIMITED WARRANTY**

**DAYTON ONE-YEAR LIMITED WARRANTY.** All Dayton® product models covered in this manual are warranted by Dayton Electric Mfg. Co. ("Dayton") to the original user against defects in workmanship or materials under normal use for one year after date of purchase. If the Dayton product is part of a set, only the portion that is defective is subject to this warranty. Any product or part which is determined to be defective in material or workmanship and returned to an authorized service location, as Dayton or Dayton's designee designates, shipping costs prepaid, will be, as the exclusive remedy, repaired or replaced with a new or reconditioned product or part of equal utility or a full refund given, at Dayton's or Dayton's designee's option, at no charge. For limited warranty claim procedures, see "Warranty Service" below. This warranty is void if there is evidence of misuse, mis-repair, mis-installation, abuse or alteration. This warranty does not cover normal wear and tear of Dayton products or portions of them, or products or portions of them which are consumable in normal use. This limited warranty gives purchasers specific legal rights, and you may also have other rights which vary from jurisdiction to jurisdiction.

### **WARRANTY DISCLAIMERS AND LIMITATIONS OF LIABILITY RELATING TO ALL CUSTOMERS FOR ALL PRODUCTS**

**LIMITATION OF LIABILITY.** TO THE EXTENT ALLOWABLE UNDER APPLICABLE LAW, DAYTON'S LIABILITY FOR CONSEQUENTIAL AND INCIDENTAL DAMAGES IS EXPRESSLY DISCLAIMED. DAYTON'S LIABILITY IN ALL EVENTS IS LIMITED TO AND SHALL NOT EXCEED THE PURCHASE PRICE PAID.

**WARRANTY DISCLAIMER.** A DILIGENT EFFORT HAS BEEN MADE TO PROVIDE PRODUCT INFORMATION AND ILLUSTRATE THE PRODUCTS IN THIS LITERATURE ACCURATELY; HOWEVER, SUCH INFORMATION AND ILLUSTRATIONS ARE FOR THE SOLE PURPOSE OF IDENTIFICATION, AND DO NOT EXPRESS OR IMPLY A WARRANTY THAT THE PRODUCTS ARE MERCHANTABILITY, OR FIT FOR A PARTICULAR PURPOSE, OR THAT THE PRODUCTS WILL NECESSARILY CONFORM TO THE ILLUSTRATIONS OR DESCRIPTIONS. EXCEPT AS PROVIDED BELOW, NO WARRANTY OR AFFIRMATION OF FACT, EXPRESSED OR IMPLIED, OTHER THAN AS STATED IN THE "LIMITED WARRANTY" ABOVE IS MADE OR AUTHORIZED BY DAYTON.

**PRODUCT SUITABILITY.** MANY JURISDICTIONS HAVE CODES AND REGULATIONS GOVERNING SALES, CONSTRUCTION, INSTALLATION, AND/OR USE OF PRODUCTS FOR CERTAIN PURPOSES, WHICH MAY VARY FROM THOSE IN NEIGHBORING AREAS. WHILE ATTEMPTS ARE MADE TO ASSURE THAT DAYTON PRODUCTS COMPLY WITH SUCH CODES, DAYTON CANNOT GUARANTEE COMPLIANCE, AND CANNOT BE RESPONSIBLE FOR HOW THE PRODUCT IS INSTALLED OR USED. BEFORE PURCHASE AND USE OF A PRODUCT, REVIEW THE SAFETY/SPECIFICATIONS, AND ALL APPLICABLE NATIONAL AND LOCAL CODES AND REGULATIONS, AND BE SURE THAT THE PRODUCT, INSTALLATION, AND USE WILL COMPLY WITH THEM.

**CONSUMERS ONLY.** CERTAIN ASPECTS OF DISCLAIMERS ARE NOT APPLICABLE TO CONSUMER PRODUCTS SOLD TO CONSUMERS; (A) SOME JURISDICTIONS DO NOT ALLOW THE EXCLUSION OR LIMITATION OF INCIDENTAL OR CONSEQUENTIAL DAMAGES, SO THE ABOVE LIMITATION OR EXCLUSION MAY NOT APPLY TO YOU; (B) ALSO, SOME JURISDICTIONS DO NOT ALLOW A LIMITATION ON HOW LONG AN IMPLIED WARRANTY LASTS, SO THE ABOVE LIMITATION MAY NOT APPLY TO YOU; AND (C) BY LAW, DURING THE PERIOD OF THIS LIMITED WARRANTY, ANY IMPLIED WARRANTIES OF MERCHANTABILITY OR FITNESS FOR A PARTICULAR PURPOSE APPLICABLE TO CONSUMER PRODUCTS PURCHASED BY CONSUMERS, MAY NOT BE EXCLUDED OR OTHERWISE DISCLAIMED.

THIS LIMITED WARRANTY ONLY APPLIES TO UNITED STATES PURCHASERS FOR DELIVERY IN THE UNITED STATES.

### **WARRANTY SERVICE**

To obtain warranty service if you purchased the covered product directly from W.W. Grainger, Inc. ("Grainger"), (i) write or call or visit the local Grainger branch from which the product was purchased or another Grainger branch near you (see [www.grainger.com](http://www.grainger.com) for a listing of Grainger branches); or (ii) contact Grainger by going to [www.grainger.com](http://www.grainger.com) and clicking on the "Contact Us" link at the top of the page, then clicking on the "Email us" link; or (iii) call Customer Care (toll free) at 1-888-361-8649. To obtain warranty service if you purchased the covered product from another distributor or retailer, (i) go to [www.grainger.com](http://www.grainger.com) for Warranty Service; (ii) write or call or visit a Grainger branch near you; or (iii) call Customer Care (toll free) at 1-888-361-8649. In any case, you will need to provide, to the extent available, the purchase date, the original invoice number, the stock number, a description of the defect, and anything else specified in this Dayton One-Year Limited Warranty. You may be required to send the product in for inspection at your cost. You can follow up on the progress of inspections and corrections in the same ways. Title and risk of loss pass to buyer on delivery to common carrier, so if product was damaged in transit to you, file claim with carrier, not retailer, Grainger or Dayton. For warranty information for purchasers and/or delivery outside the United States, please use the following applicable contact information:

**Dayton Electric Mfg. Co.,  
100 Grainger Parkway, Lake Forest, IL 60045 U.S.A.  
or call +1-888-361-8649**