

ADJUSTABLE WORK-MATE STAND, ALUMINUM - AHT-L-2448-A

APPROX WEIGHT: 59.24 lbs.
 DOES NOT INCLUDE WEIGHT OF POWER OR PACKAGING!!!

*** ANY ADDITIONS, DELETIONS, OR OMISSIONS MUST BE CORRECTED ON THIS DRAWING AS THIS DRAWING WILL BE CONSIDERED ALL INCLUSIVE ***
 ALL GRAPHICS PROVIDED ARE FOR REFERENCE ONLY. IF CERTAIN DIMENSIONS ARE CRITICAL PLEASE VERIFY THOSE DIMENSIONS WITH YOUR SALESPERSON

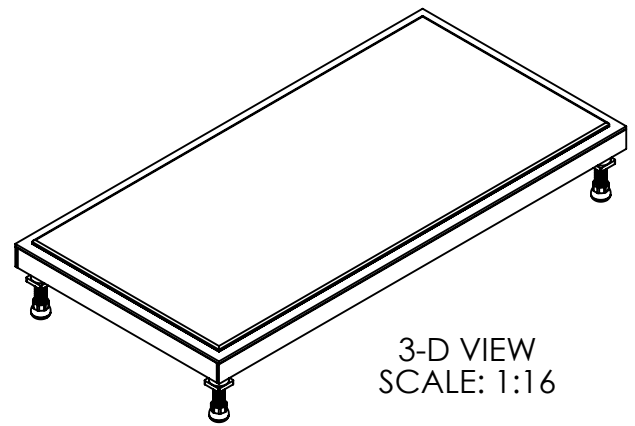
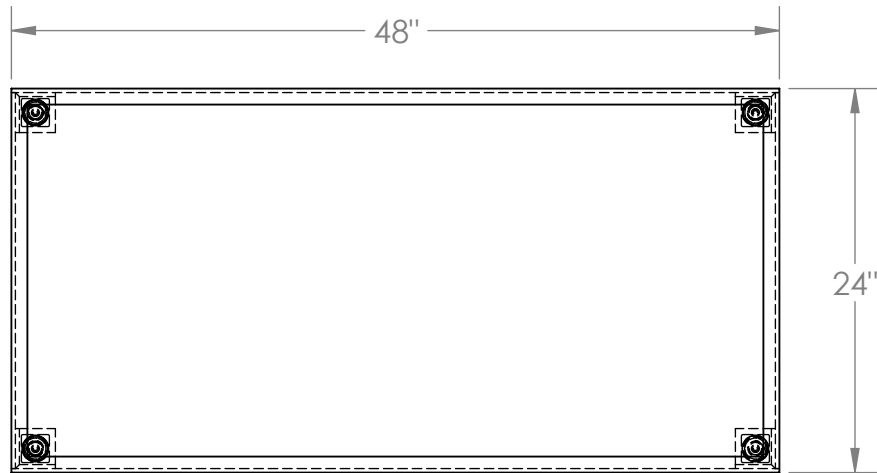

3-D VIEW
 SCALE: 1:16

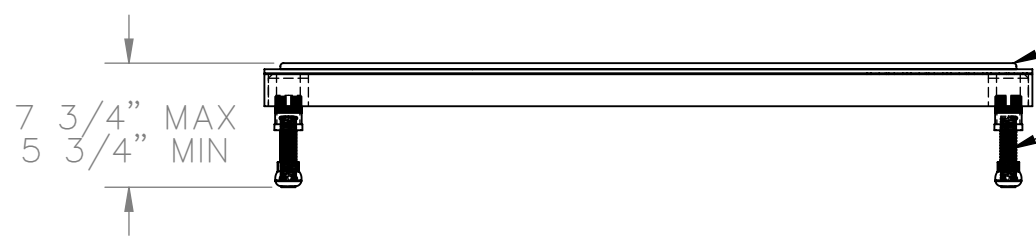

ERGO-MATting DECK
 (MAT SIZE 22" x 46")
 HEIGHT ADJUSTED BY
 ROTATING THREADED LEGS
 (SHOWN AT MAX HEIGHT)

DIMENSION TOLERANCE ± 1/4"

STANDARD FEATURES

- MODEL NUMBER : AHT-L-2448-A
- CAPACITY: 500 LBS.
- DECK WIDTH: 24"
- DECK LENGTH: 48"
- RAISED HEIGHT: 7 3/4"
- LOWERED HEIGHT: 5 3/4"
- ALUMINUM PLATFORM WITH POWDER COATED STEEL LEGS
- ERGO MATting IS BLUE

SPECIAL FEATURES

NONE

FOR INTERNAL USE ONLY PROJECT SIGN OFF	
SALES	
ENG.	
FAB.	
POWER	

APPROVAL

I, THE UNDERSIGNED, AGREE THAT THE PRODUCT AS REPRESENTED SATISFIES DESIGN AND DIMENSION REQUIREMENTS. I ALSO ACKNOWLEDGE MY DUTY TO CONFIRM PRODUCT AND INSTALLATION COMPLIANCE WITH ALL APPLICABLE FEDERAL, STATE AND LOCAL REGULATIONS AND STANDARDS.

ANY MODIFIED UNITS ARE NON-RETURNABLE

[] As drawn [] As marked

Signed: _____ Date: _____

Printed Name: _____

LEAD TIME WILL START UPON RECEIPT OF SIGNED APPROVAL DRAWING

DISTRIBUTOR'S NAME:		P.O.#
VESTIL MANUFACTURING		X
DRAWN BY: MTS	DATE: 10/13/14	W.O.#
REFERENCE: X	SCALE: 1:12	X
QUOTED LEAD TIME: X	QUOTE #	SALES: X
	X	FILE NAME:
		14-007-284