

# COUNTER-BALANCED PALLET MASTER/SERVER - CB-PMPS-6-50-AIR

APPROX WEIGHT: 2095.77 lbs.  
 DOES NOT INCLUDE WEIGHT OF POWER OR PACKAGING!!!

\*\*\* ANY ADDITIONS, DELETIONS, OR OMISSIONS MUST BE CORRECTED ON THIS DRAWING AS THIS DRAWING WILL BE CONSIDERED ALL INCLUSIVE \*\*\*

ALL GRAPHICS PROVIDED ARE FOR REFERENCE ONLY. IF CERTAIN DIMENSIONS ARE CRITICAL PLEASE VERIFY THOSE DIMENSIONS WITH YOUR SALESPERSON

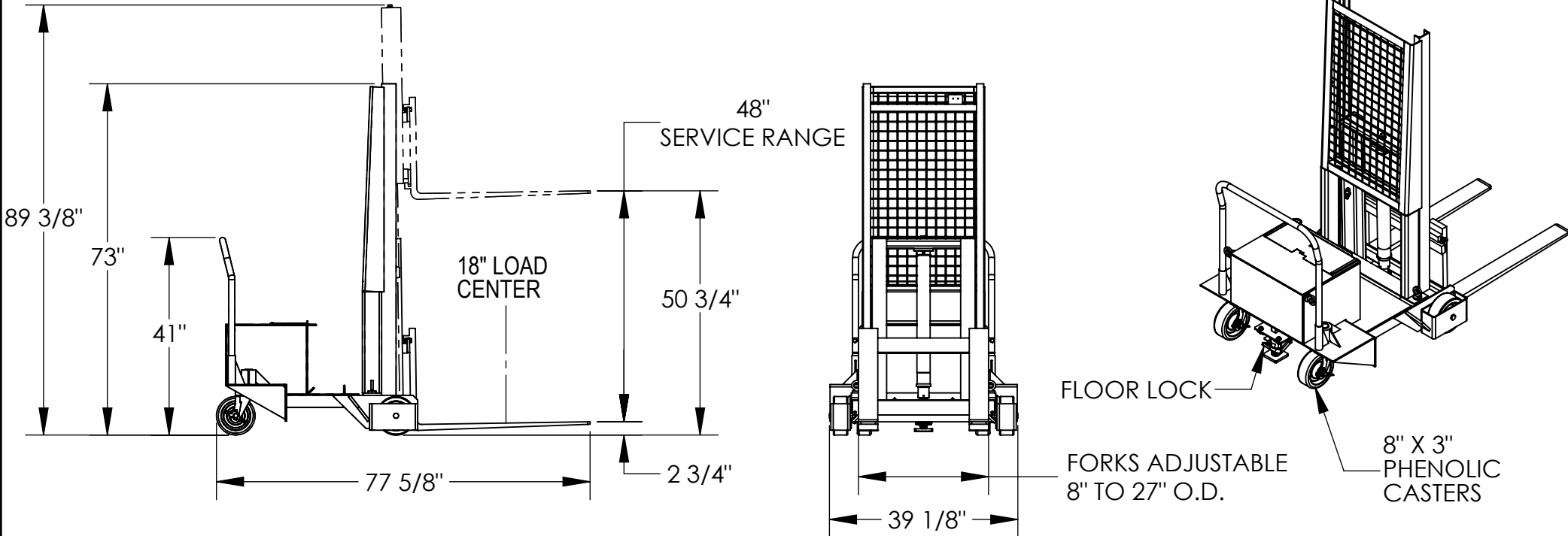

DIMENSION TOLERANCE ± 1/4"

## STANDARD FEATURES

MODEL NUMBER IS CB-PMPS-6-50-AIR  
 COUNTER-BALANCED DESIGN  
 OVERALL WIDTH IS 39 1/8"  
 OVERALL LENGTH IS 77 5/8"  
 OVERALL RAISED HEIGHT IS 89 3/8"  
 OVERALL LOWERED HEIGHT IS 73"  
 FORK RAISED HEIGHT IS 50 3/4"  
 FORK LOWERED HEIGHT IS 2 3/4"  
 MAXIMUM CAPACITY IS 600 LBS  
 FORKS ARE 4" WIDE x 36" LONG  
 MAXIMUM FORK SPREAD IS 27" O.D.  
 FLOOR LOCK  
 RECIPROCATING AIR POWER HYDRAULIC  
 15 CFM @ 100 PSI (1/4 GPM)  
 FOOT TREADLE CONTROL  
 ALL STEEL CONSTRUCTION  
 (ASTM A-36 MINIMUM)  
 DURABLE LIQUID PAINT BLUE FINISH

## PLEASE CIRCLE SPECIFICATIONS:

POWER	<input type="checkbox"/> AC	<input type="checkbox"/> DC (12V)	<input checked="" type="checkbox"/> AIR/OIL	
MOTOR VOLTAGE	<input type="checkbox"/> 115	<input type="checkbox"/> 208	<input type="checkbox"/> 230	<input type="checkbox"/> 460
DEDICATED CIRCUIT REQUIRED				
MOTOR PHASE	<input type="checkbox"/> SINGLE		<input type="checkbox"/> THREE	
CONTROL	<input type="checkbox"/> HAND		<input type="checkbox"/> FOOT	
BATTERY CHRG.	<input type="checkbox"/> REMOTE		<input type="checkbox"/> ON-BOARD	
CHRG. INDICATOR	<input type="checkbox"/> YES		<input type="checkbox"/> NO	

## SPECIAL FEATURES

NONE

USE ON LEVEL SURFACES ONLY

APPROVAL

I, THE UNDERSIGNED, AGREE THAT THE PRODUCT AS REPRESENTED SATISFIES DESIGN AND DIMENSION REQUIREMENTS. I ALSO ACKNOWLEDGE MY DUTY TO CONFIRM PRODUCT AND INSTALLATION COMPLIANCE WITH ALL APPLICABLE FEDERAL, STATE AND LOCAL REGULATIONS AND STANDARDS.  
**UNITS REQUIRING APPROVAL DRAWINGS OR MODIFIED ARE NON-RETURNABLE**

[ ] As drawn [ ] As marked

Signed: \_\_\_\_\_ Date: \_\_\_\_\_

Printed Name: \_\_\_\_\_

LEAD TIME WILL START UPON RECEIPT OF SIGNED APPROVAL DRAWING

DISTRIBUTOR'S NAME:		P.O.#
VESTIL MANUFACTURING		X
DRAWN BY: KGH		W.O.#
DATE: 7/6/2016		X
REFERENCE: X	SCALE: 1:30	SALES: X
QUOTED LEAD TIME: X	QUOTE #	FILE NAME:
	X	15-007-108-002