

CROSS-OVER LADDER - COL-5-46-33-HDG

APPROX WEIGHT: 392.49 lbs.
DOES NOT INCLUDE WEIGHT OF POWER OR PACKAGING!!!

*** ANY ADDITIONS, DELETIONS, OR OMISSIONS MUST BE CORRECTED ON THIS DRAWING AS THIS DRAWING WILL BE CONSIDERED ALL INCLUSIVE ***

ALL GRAPHICS PROVIDED ARE FOR REFERENCE ONLY. IF CERTAIN DIMENSIONS ARE CRITICAL PLEASE VERIFY THOSE DIMENSIONS WITH YOUR SALESPERSON

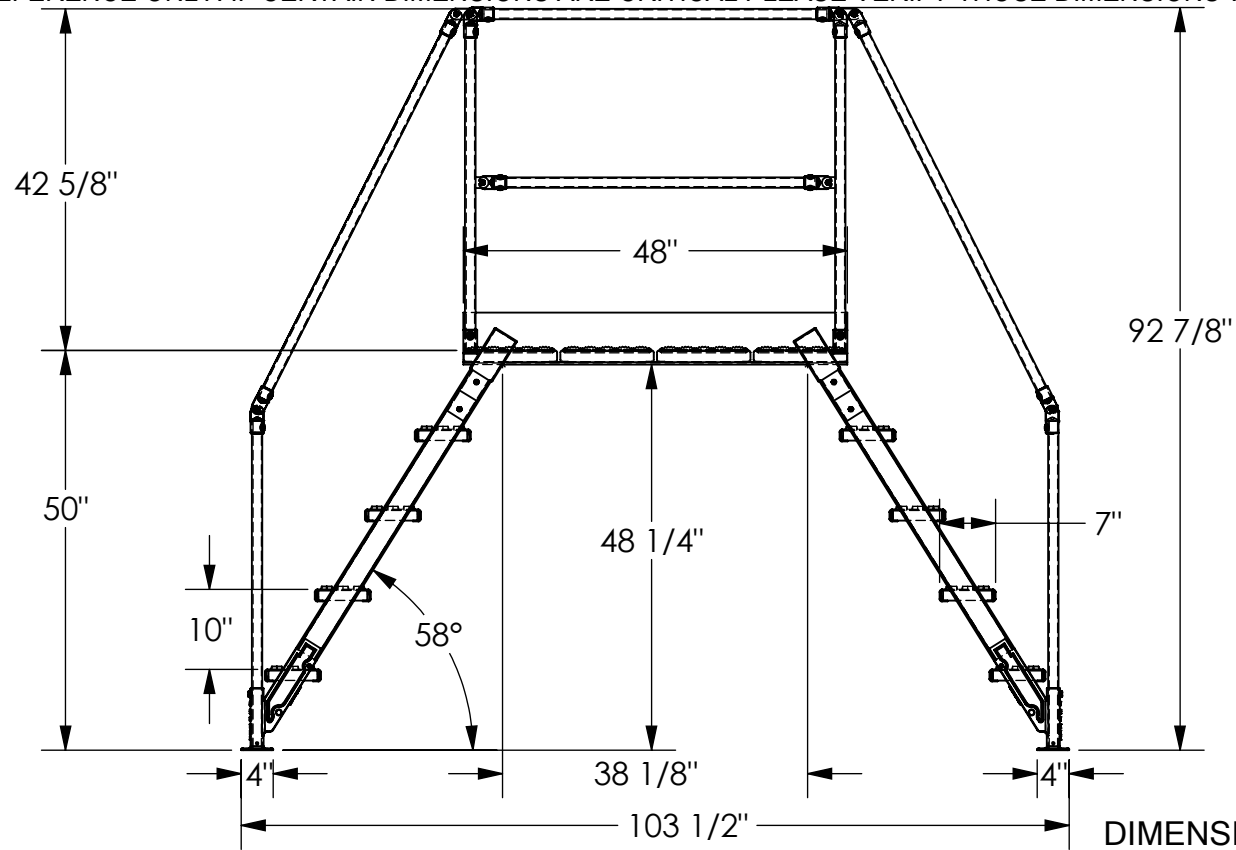
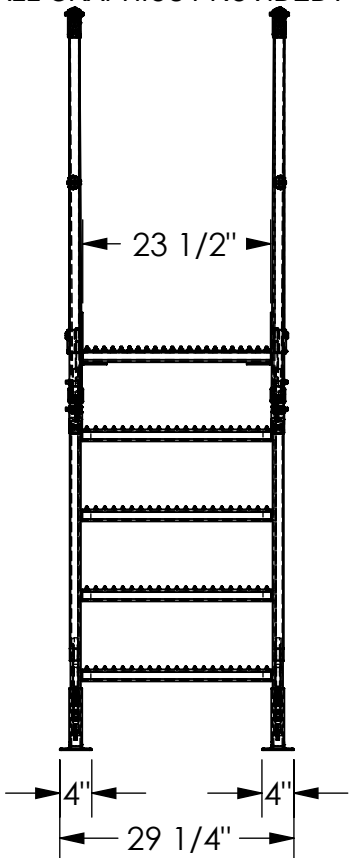

DIMENSION TOLERANCE ± 1/4"

STANDARD FEATURES

- MODEL NUMBER: COL-5-46-33-HDG
- OVERALL SIZE:
29 1/4" W x 103 1/2" L x 92 7/8" H
- CLEARANCE SPAN:
38 1/8" W x 48 1/4" H
- TOP PLATFORM HEIGHT: 50"
- STEP HEIGHT SPACING: 10"
- STEP DEPTH: 7"
- STEP & PLATFORM WIDTH 23 1/2"
- CLIMB ANGLE: 58°
- HOT DIPPED GALVANIZED FINISH
- ALL STEPS & PLATFORM ARE
SERRATED STEEL
- KNOCK-DOWN HANDRAILING
(UNIT SHIPS KNOCKED DOWN,
ASSEMBLY REQUIRED)

SPECIAL FEATURES

NONE

NOTE

- UNIT MUST BE ANCHORED TO THE FLOOR!!!
- Ø7/16" MOUNTING HOLES
- 8 TOTAL MOUNTING HOLES PER STANDARD UNIT
- 2 MOUNTING HOLES PER CORNER BRACKET

I, THE UNDERSIGNED, AGREE THAT THE PRODUCT AS REPRESENTED SATISFIES DESIGN AND DIMENSION REQUIREMENTS. I ALSO ACKNOWLEDGE MY DUTY TO CONFIRM PRODUCT AND INSTALLATION COMPLIANCE WITH ALL APPLICABLE FEDERAL, STATE AND LOCAL REGULATIONS AND STANDARDS.

UNITS REQUIRING APPROVAL DRAWINGS OR MODIFIED ARE NON-RETURNABLE

As drawn As marked

Signed: _____ Date: _____

Printed Name: _____

LEAD TIME WILL START UPON RECEIPT OF SIGNED APPROVAL DRAWING

DISTRIBUTOR'S NAME:		P.O.#
VESTIL MANUFACTURING		X
DRAWN BY: BCN	DATE: 4/29/2016	W.O.#
REFERENCE: X	SCALE: 1:24	X
QUOTED LEAD TIME: X	QUOTE #	SALES: X
	X	FILE NAME:
		44-007-738