

# DRUM CARRIER/ROTATOR: DCT-85-4WFP

APPROX WEIGHT: 127 lbs.  
 DOES NOT INCLUDE WEIGHT OF POWER OR PACKAGING!!!

\*\*\* ANY ADDITIONS, DELETIONS, OR OMISSIONS MUST BE CORRECTED ON THIS DRAWING AS THIS DRAWING WILL BE CONSIDERED ALL INCLUSIVE \*\*\*

ALL GRAPHICS PROVIDED ARE FOR REFERENCE ONLY. IF CERTAIN DIMENSIONS ARE CRITICAL PLEASE VERIFY THOSE DIMENSIONS WITH YOUR SALESPERSON

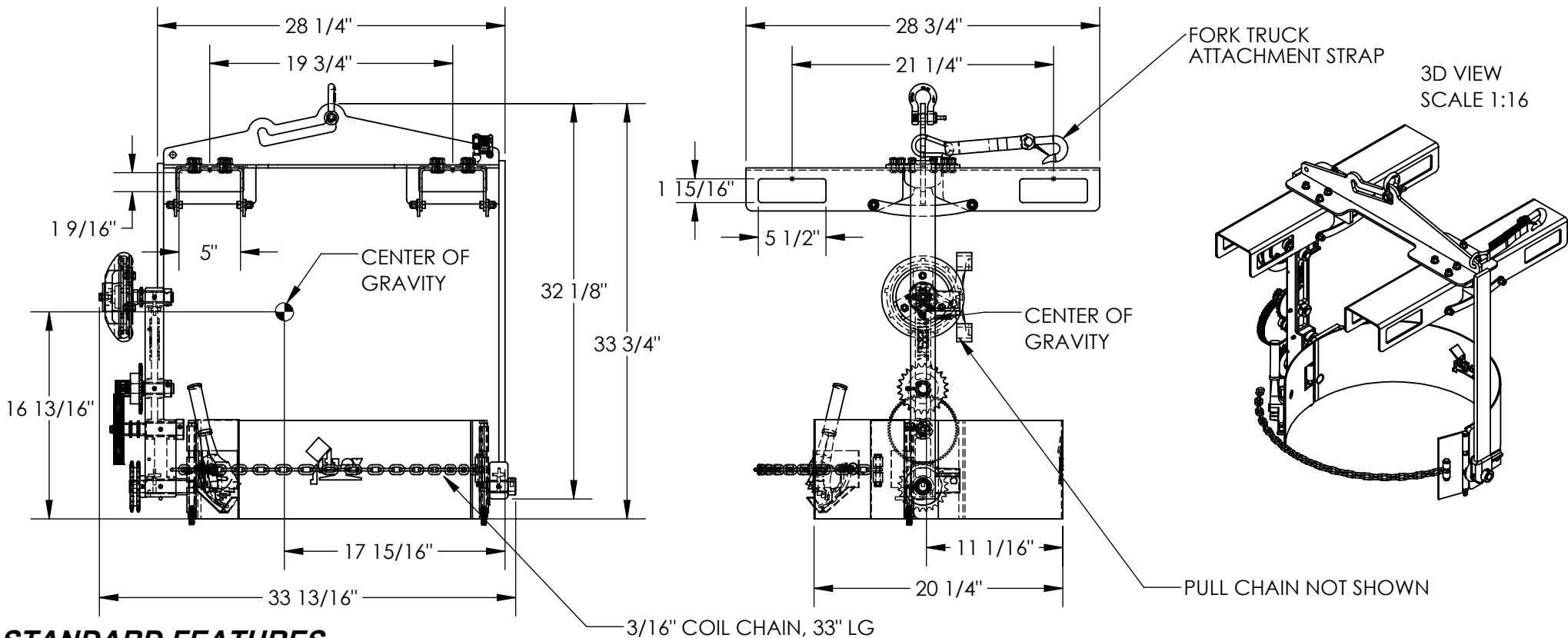

## STANDARD FEATURES

- MODEL NUMBER: DCT-85-4WFP
- ROTATION METHOD: 15' CHAIN
- ACCEPTS 55 GALLON STEEL DRUMS
- MAX. CAPACITY: 1,500 LBS.
- BOLT-ON FORK POCKETS FOR 4-WAY ENTRY
- 5"W x 1 9/16"H FORK POCKETS ON 19 3/4" CENTERS
- 5 1/2"W x 1 15/16"H FORK POCKETS ON 21 1/4" CENTERS
- FORK TRUCK ATTACHMENT STRAP
- TWO POSITION LIFTING BAIL
- DURABLE LIQUID PAINT BLUE FINISH

HORIZONTAL CENTER OF GRAVITY: 11 1/16"  
 VERTICAL CENTER OF GRAVITY: 16 13/16"  
 LOST LOAD: 127 LBS.

## OPTIONS (AVAILABLE AT EXTRA COST)

- HAND CRANK: DCT-R-HC
- FIBER DRUM ADAPTER: FDA-800
- 30 GALLON STEEL SADDLE: FDC-30

## SPECIAL FEATURES

NONE

DIMENSION TOLERANCE ± 1/4"

APPROVAL	I, THE UNDERSIGNED, AGREE THAT THE PRODUCT AS REPRESENTED SATISFIES DESIGN AND DIMENSION REQUIREMENTS. I ALSO ACKNOWLEDGE MY DUTY TO CONFIRM PRODUCT AND INSTALLATION COMPLIANCE WITH ALL APPLICABLE FEDERAL, STATE AND LOCAL REGULATIONS AND STANDARDS.	
	ANY MODIFIED UNITS ARE NON-RETURNABLE	
	[ ] As drawn	[ ] As marked
	Signed: _____ Date: _____	
Printed Name: _____		
LEAD TIME WILL START UPON RECEIPT OF SIGNED APPROVAL DRAWING		

FOR INTERNAL USE ONLY PROJECT SIGN OFF	
SALES	
ENG.	
FAB.	
POWER	

DISTRIBUTOR'S NAME:		P.O.#
VESTIL MANUFACTURING		X
DRAWN BY: TJM		DATE: 04/30/19
REFERENCE: X		SCALE: 1:12
QUOTED LEAD TIME: X		QUOTE #
		X
		SALES: X
		FILE NAME:
		40-007-114