

DRUM STORAGE RACK - DRK-2-2

APPROX WEIGHT: 158.21 lbs.
DOES NOT INCLUDE WEIGHT OF POWER OR PACKAGING!!!

*** ANY ADDITIONS, DELETIONS, OR OMISSIONS MUST BE CORRECTED ON THIS DRAWING AS THIS DRAWING WILL BE CONSIDERED ALL INCLUSIVE ***

ALL GRAPHICS PROVIDED ARE FOR REFERENCE ONLY. IF CERTAIN DIMENSIONS ARE CRITICAL PLEASE VERIFY THOSE DIMENSIONS WITH YOUR SALESPERSON

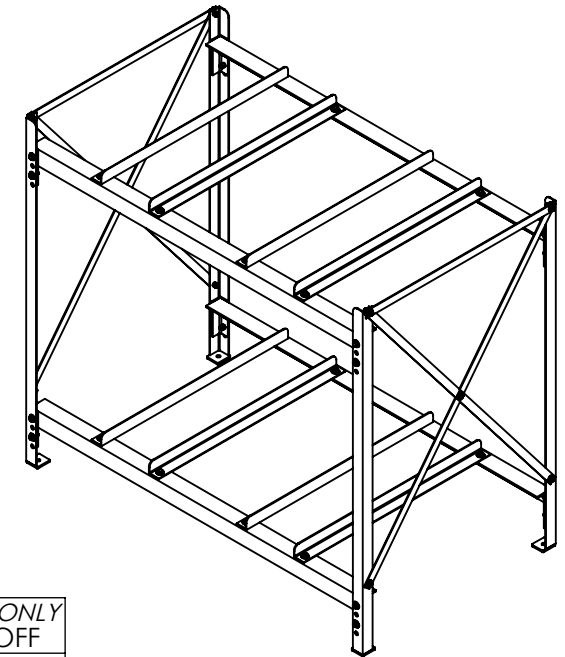
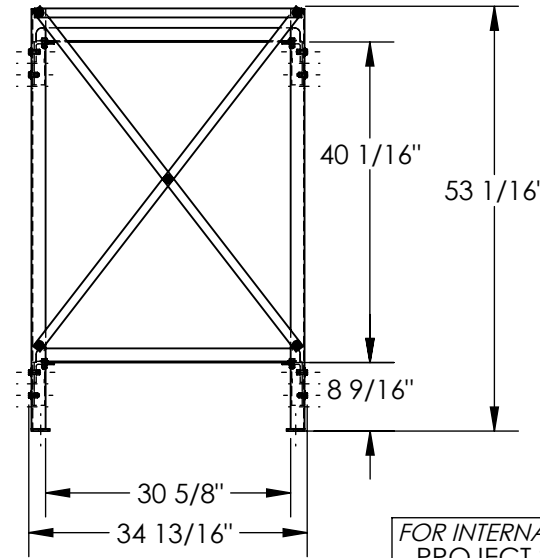
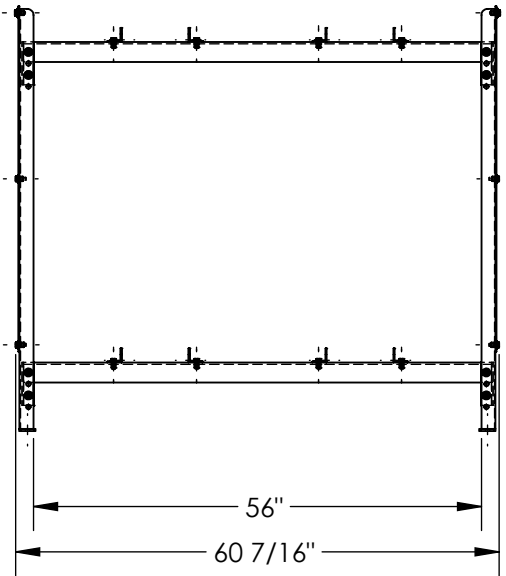

STANDARD FEATURES

MODEL NUMBER IS DRK-2-2
OVERALL WIDTH IS 60 7/16"
USABLE WIDTH IS 56"
OVERALL LENGTH IS 34 13/16"
USABLE LENGTH IS 30 5/8"
OVERALL HEIGHT IS 53 1/16"
MAX CAPACITY IS 3,200 LBS.
CAPACITY PER SHELF: 1,600 LBS.
CONSTRUCTED OF HEAVY DUTY STEEL ANGLE
CROSS BRACING IS PROVIDED FOR EXTRA STRENGTH
ALLOWS FORKLIFT ENTRY FROM THE FRONT OR REAR
UPRIGHTS KEEP DRUMS FROM ACCIDENTAL ROLL OFF
ROUNDED CRADLE EDGES PREVENT DRUMS FROM PUNCTURE
(4) ANCHOR PADS HELP TO PREVENT TIPPING
FRAME: TOUGH BAKED IN POWDER COATED YELLOW FINISH
CROSS BRACES: TOUGH BAKED IN POWDER COATED BLUE FINISH
SHIPS KNOCKED DOWN

SPECIAL FEATURES

NONE

| FOR INTERNAL USE ONLY PROJECT SIGN OFF | |
|-------------------------------------------|--|
| SALES | |
| ENG. | |
| FAB. | |
| POWER | |

DIMENSION TOLERANCE ± 1/4"

| | | |
|---------------------------------------------------------------------|----------------------------------------------------------------------------------------------------------------------------------------------------------------------------------------------------------------------------------------------------------|-------------|
| APPROVAL | I, THE UNDERSIGNED, AGREE THAT THE PRODUCT AS REPRESENTED SATISFIES DESIGN AND DIMENSION REQUIREMENTS. I ALSO ACKNOWLEDGE MY DUTY TO CONFIRM PRODUCT AND INSTALLATION COMPLIANCE WITH ALL APPLICABLE FEDERAL, STATE AND LOCAL REGULATIONS AND STANDARDS. | |
| | ANY MODIFIED UNITS ARE NON-RETURNABLE [] As drawn [] As marked | |
| | Signed: _____ | Date: _____ |
| | Printed Name: _____ | |
| LEAD TIME WILL START UPON RECEIPT OF SIGNED APPROVAL DRAWING | | |

| | | |
|-----------------------------|-------------|------------|
| DISTRIBUTOR'S NAME: | | P.O.# |
| VESTIL MANUFACTURING | | X |
| | | W.O.# |
| DRAWN BY: THW | | X |
| DATE: 07/10/19 | | SALES: X |
| REFERENCE: X | SCALE: 1:24 | FILE NAME: |
| QUOTED LEAD TIME: X | QUOTE # X | 40-007-084 |