

DRUM STORAGE RACK - DRK-3-2

APPROX WEIGHT: 209.34 lbs.
 DOES NOT INCLUDE WEIGHT OF POWER OR PACKAGING!!!

*** ANY ADDITIONS, DELETIONS, OR OMISSIONS MUST BE CORRECTED ON THIS DRAWING AS THIS DRAWING WILL BE CONSIDERED ALL INCLUSIVE ***

ALL GRAPHICS PROVIDED ARE FOR REFERENCE ONLY. IF CERTAIN DIMENSIONS ARE CRITICAL PLEASE VERIFY THOSE DIMENSIONS WITH YOUR SALESPERSON

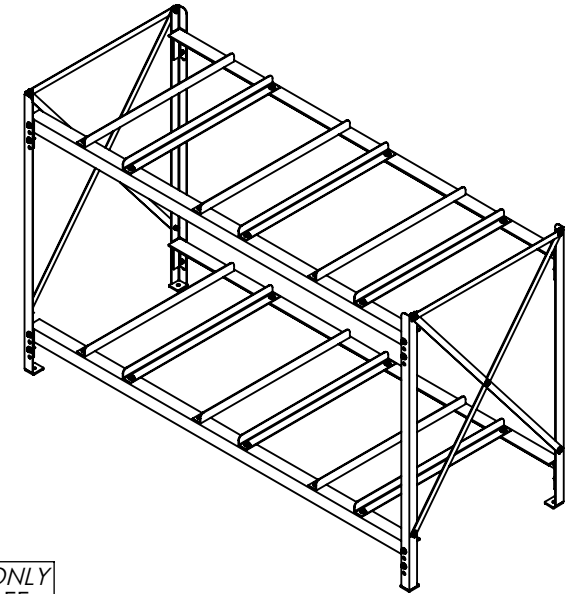
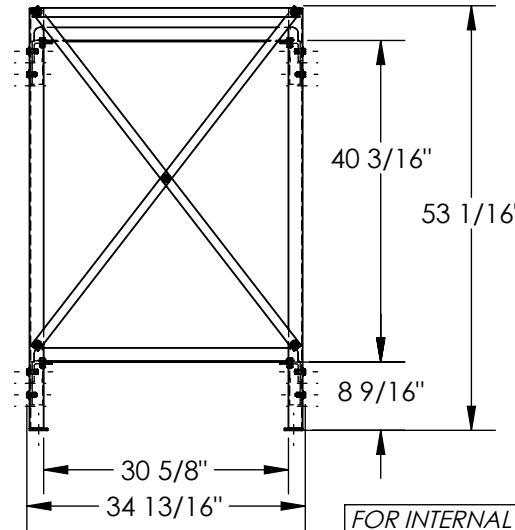
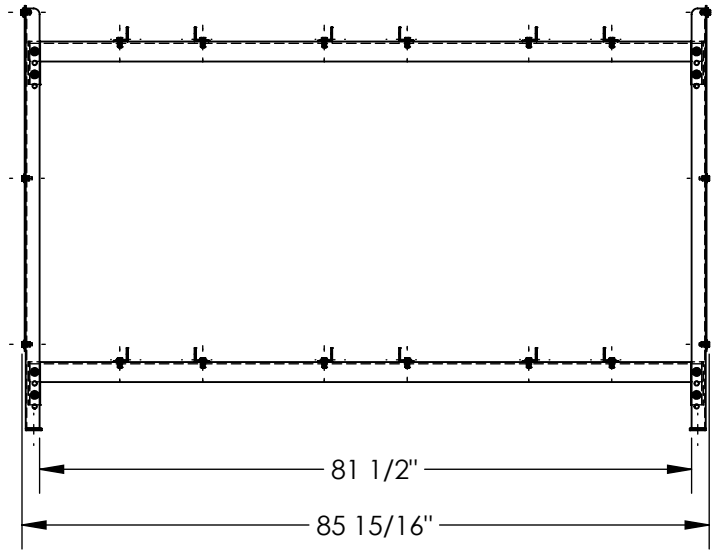

STANDARD FEATURES

MODEL NUMBER IS DRK-3-2
 OVERALL WIDTH IS 85 15/16"
 USABLE WIDTH IS 81 1/2"
 OVERALL LENGTH IS 34 13/16"
 USABLE LENGTH IS 30 5/8"
 OVERALL HEIGHT IS 53 1/16"
 MAX CAPACITY IS 4,800 LBS
 CAPACITY PER SHELF: 2,400 LBS.
 CONSTRUCTED OF HEAVY DUTY STEEL ANGLE
 CROSS BRACING IS PROVIDED FOR EXTRA STRENGTH
 ALLOWS FORKLIFT ENTRY FROM THE FRONT OR REAR
 UPRIGHTS KEEP DRUMS FROM ACCIDENTAL ROLL OFF
 ROUNDED CRADLE EDGES PREVENT DRUMS FROM PUNCTURE
 (4) ANCHOR PADS HELP TO PRVENT TIPPING
 FRAME: TOUGH BAKED IN POWDER COATED YELLOW FINISH
 CROSS BRACES: TOUGH BAKED IN POWDER COATED BLUE FINISH
 SHIPS KNOCKED DOWN

SPECIAL FEATURES

NONE

FOR INTERNAL USE ONLY PROJECT SIGN OFF	
SALES	
ENG.	
FAB.	
POWER	

DIMENSION TOLERANCE ± 1/4"

APPROVAL	I, THE UNDERSIGNED, AGREE THAT THE PRODUCT AS REPRESENTED SATISFIES DESIGN AND DIMENSION REQUIREMENTS. I ALSO ACKNOWLEDGE MY DUTY TO CONFIRM PRODUCT AND INSTALLATION COMPLIANCE WITH ALL APPLICABLE FEDERAL, STATE AND LOCAL REGULATIONS AND STANDARDS.	
	ANY MODIFIED UNITS ARE NON-RETURNABLE	
	[] As drawn [] As marked	
	Signed: _____ Date: _____	
Printed Name: _____		
LEAD TIME WILL START UPON RECEIPT OF SIGNED APPROVAL DRAWING		

DISTRIBUTOR'S NAME:		P.O.#
VESTIL MANUFACTURING		X
		W.O.#
DRAWN BY: THW		X
DATE: 07/10/19		SALES: X
REFERENCE: X	SCALE: 1:24	FILE NAME:
QUOTED LEAD TIME: X	QUOTE # X	40-007-085