

ELECTRIC CHAIN HOIST: H-2000-1

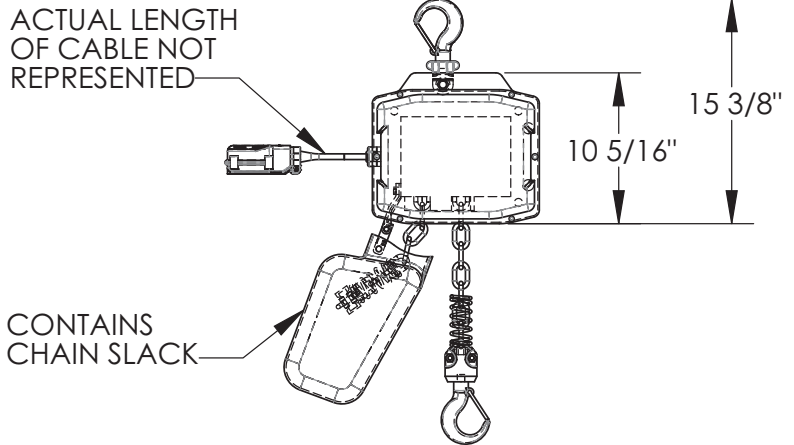
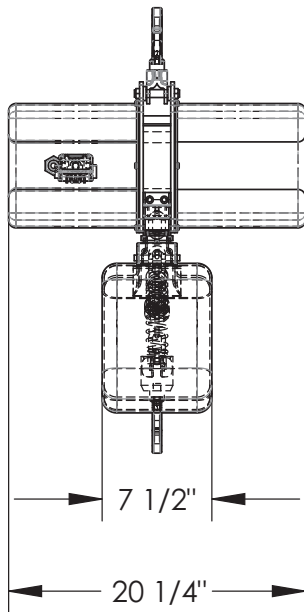
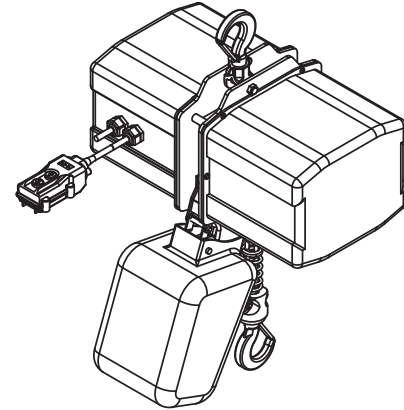
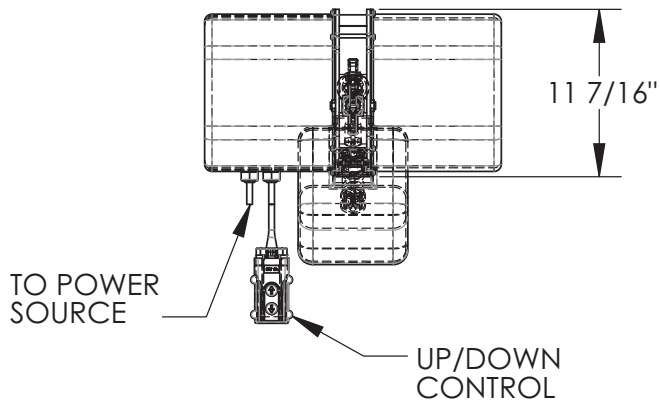

ALL SPECIAL UNITS ARE NON-RETURNABLE DIMENSION TOLERANCE $\pm 1/2"$

ANY ADDITIONS, DELETIONS, OR OMISSIONS MUST BE CORRECTED ON THIS DRAWING AS THIS DRAWING WILL BE CONSIDERED ALL INCLUSIVE

ALL GRAPHICS PROVIDED ARE FOR REFERENCE ONLY. IF CERTAIN DIMENSIONS ARE CRITICAL PLEASE VERIFY THOSE DIMENSIONS WITH YOUR SALESPERSON

PLEASE CIRCLE SPECIFICATIONS:

POWER	AC	DC (12V)	AIR/OIL
MOTOR VOLTAGE	115	208	230 460
DEDICATED CIRCUIT REQUIRED			
MOTOR PHASE	SINGLE	THREE	
CONTROL	HAND	FOOT	
* BATTERY CHRG.	REMOTE	ON-BOARD	
* CHRG. INDICATOR	YES	NO	

* AVAILABLE AT ADDITIONAL COST

STANDARD FEATURES

MODEL NUMBER IS: H-2000-1
 APPROXIMATE WEIGHT IS: 105 LBS.
 CAPACITY IS: 2,000 LBS.
 LIFTS/LOWERS AT A RATE 17 FEET PER MINUTE
 OVERALL WIDTH IS: 20 1/4"
 OVERALL LENGTH (EXCLUDING CHAIN CONTAINER) IS: 11 7/16"
 OVERALL HEIGHT (INCLUDING UPPER SUSPENSION HOOK) IS: 15 3/8"
 15 FEET OF LIFT

SPECIAL FEATURES

NONE

APPROVAL

I, the undersigned, hereby approve this print.
 This includes my approval of design & dimensions

As drawn As marked

Signed: _____ Date: _____

LEAD TIME WILL START UPON RECEIPT OF SIGNED APPROVAL DRAWING

DISTRIBUTOR'S NAME: VESTIL MANUFACTURING		P.O.# X
DRAWN BY: TM	DATE: 03/04/21	W.O.# X
REFERENCE: X	SCALE: 1:12	SALES: X
	QUOTE # X	FILE NAME: H-2000-1