

TRANSPORTABLE JIB CRANE - JIB-P-10-8-8

APPROX WEIGHT: 640.51 lbs.
DOES NOT INCLUDE WEIGHT OF POWER OR PACKAGING!!!

*** ANY ADDITIONS, DELETIONS, OR OMISSIONS MUST BE CORRECTED ON THIS DRAWING AS THIS DRAWING WILL BE CONSIDERED ALL INCLUSIVE ***

ALL GRAPHICS PROVIDED ARE FOR REFERENCE ONLY. IF CERTAIN DIMENSIONS ARE CRITICAL PLEASE VERIFY THOSE DIMENSIONS WITH YOUR SALESPERSON

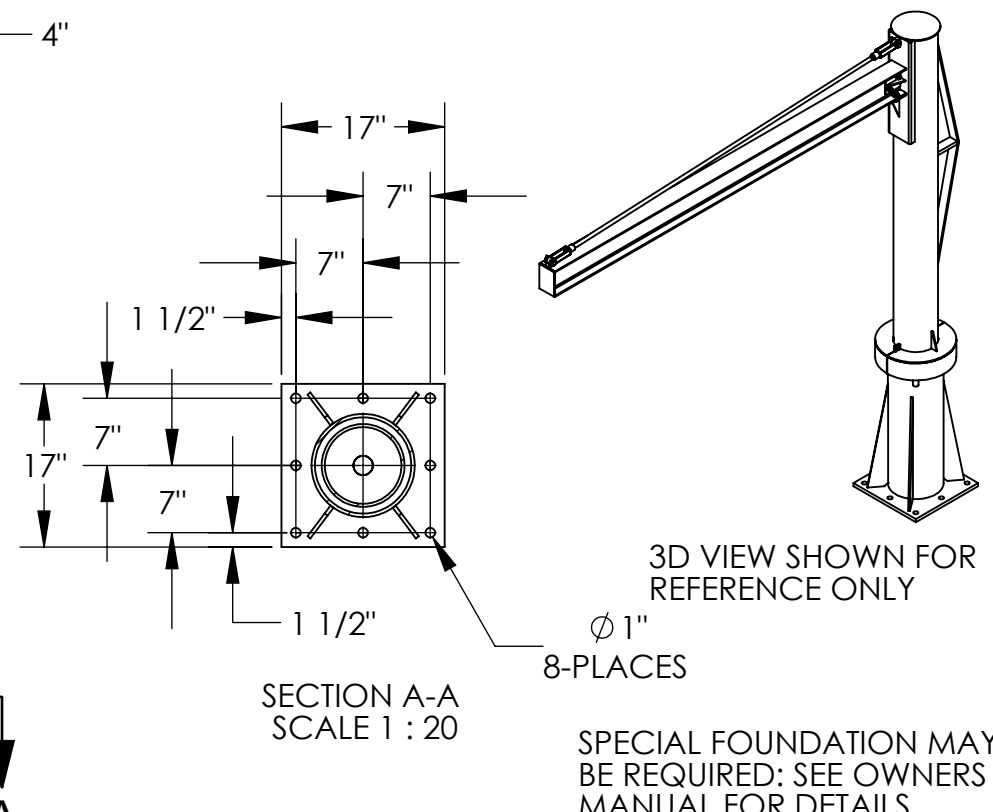
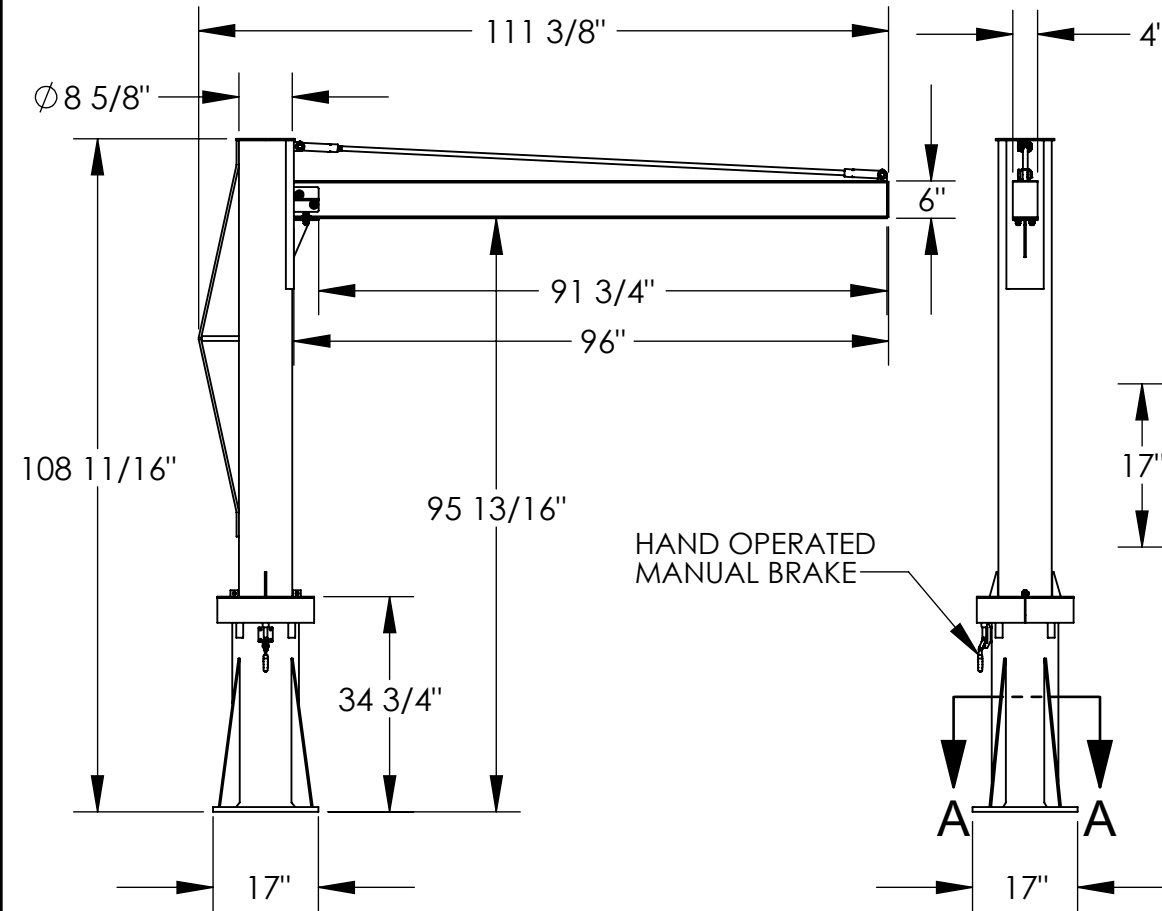

STANDARD FEATURES

- MODEL NUMBER: JIB-P-10-8-8
- CAPACITY: 1,000 POUNDS
- OVERALL LENGTH: 111 3/8"
- OVERALL BOOM LENGTH: 96"
- USABLE BOOM LENGTH: 91 3/4"
- OVERALL HEIGHT: 108 11/16"
- USABLE HEIGHT: 95 13/16"
- I-BEAM SIZE: 6" HEIGHT X 4" FLANGE WIDTH
- UPRIGHT PIPE DIAMETER: 8 5/8"
- BASE SIZE: 17" X 17" X 34 3/4"
- WITH MOUNTING HOLES: Ø 1"
- 360° CONTINUOUS ROTATION
- HAND OPERATED MANUAL BRAKE
- DURABLE LIQUID PAINT BLUE FINISH

SPECIAL FEATURES

NONE

DIMENSION TOLERANCE ± 1/4"

A P P R O V A L

I, THE UNDERSIGNED, AGREE THAT THE PRODUCT AS REPRESENTED SATISFIES DESIGN AND DIMENSION REQUIREMENTS. I ALSO ACKNOWLEDGE MY DUTY TO CONFIRM PRODUCT AND INSTALLATION COMPLIANCE WITH ALL APPLICABLE FEDERAL, STATE AND LOCAL REGULATIONS AND STANDARDS.

UNITS REQUIRING APPROVAL DRAWINGS OR MODIFIED ARE NON-RETURNABLE

[] As drawn [] As marked

Signed: _____ Date: _____

Printed Name: _____

LEAD TIME WILL START UPON RECEIPT OF SIGNED APPROVAL DRAWING

DISTRIBUTOR'S NAME:		P.O.#
VESTIL MANUFACTURING		X
DRAWN BY: ND		W.O.#
DATE: 8/14/09		X
REFERENCE: X	SCALE: 1:31	SALES: X
QUOTED LEAD TIME: X	QUOTE # X	FILE NAME:
		28-007-118