

# PORTABLE ADJ. HEIGHT WORKER STAND - PAHW-H-1936

APPROX WEIGHT: 57.35 lbs.  
 DOES NOT INCLUDE WEIGHT OF POWER OR PACKAGING!!!

\*\*\*ANY ADDITIONS, DELETIONS, OR OMISSIONS MUST BE CORRECTED ON THIS DRAWING AS THIS DRAWING WILL BE CONSIDERED ALL INCLUSIVE\*\*\*

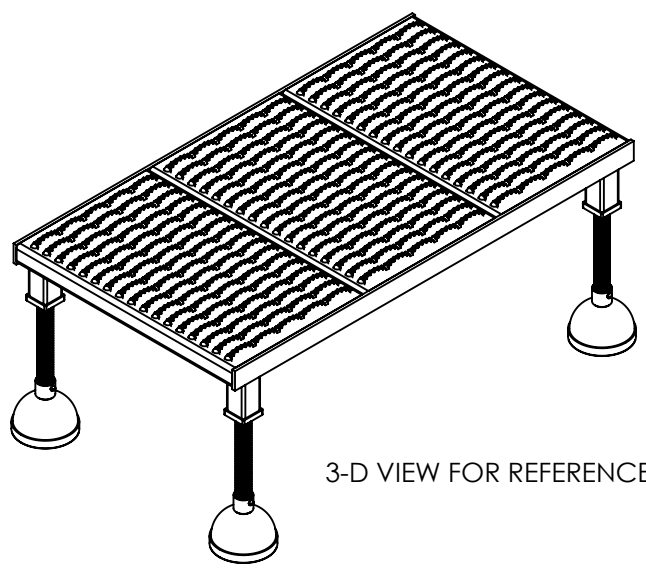
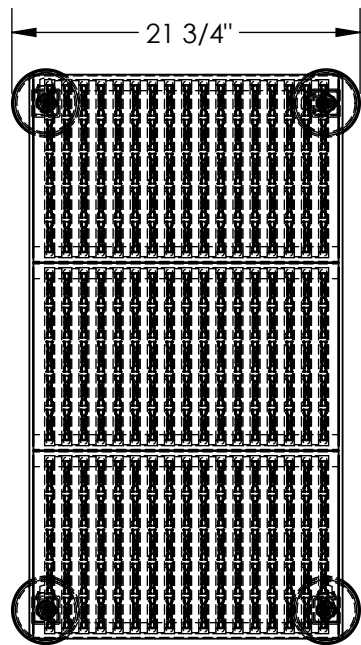

3-D VIEW FOR REFERENCE

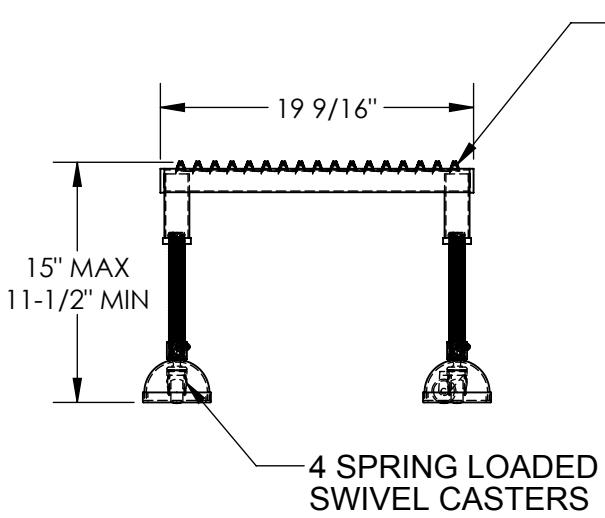

SERRATED STEEL PLATFORM FOR TRACTION

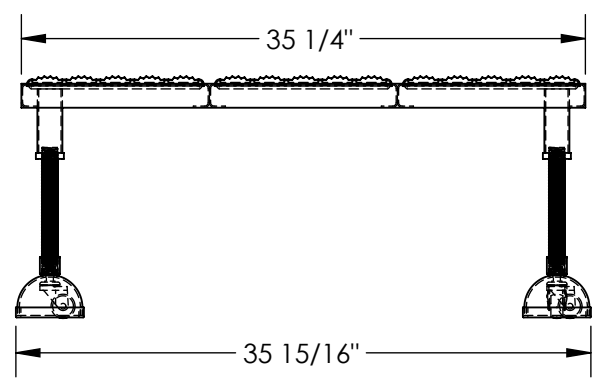

DIMENSION TOLERANCE  $\pm 1/4$ "  
 ALL GRAPHICS PROVIDED ARE FOR REFERENCE ONLY. IF CERTAIN DIMENSIONS ARE CRITICAL PLEASE VERIFY THOSE DIMENSIONS WITH YOUR SALESPERSON

FOR INTERNAL USE ONLY	
PROJECT SIGN OFF	
SALES	
ENG.	
FAB.	
POWER	

## STANDARD FEATURES

- MODEL NUMBER IS PAHW-H-1936
- CAPACITY IS 500 LBS
- OVERALL WIDTH IS 21 3/4"
- USABLE WIDTH IS 19 9/16"
- OVERALL LENGTH IS 35 15/16"
- USABLE LENGTH IS 35 1/4"
- OVERALL HEIGHT IS 11-1/2 THRU 15"
- 4 ADJUSTABLE LENGTH LEGS
- 4 SPRING LOADED SWIVEL CASTERS
- TOUGH BAKED IN POWDER COATED YELLOW FINISH

**APPROVAL**

I, THE UNDERSIGNED, AGREE THAT THE PRODUCT AS REPRESENTED SATISFIES DESIGN AND DIMENSION REQUIREMENTS. I ALSO ACKNOWLEDGE MY DUTY TO CONFIRM PRODUCT AND INSTALLATION COMPLIANCE WITH ALL APPLICABLE FEDERAL, STATE AND LOCAL REGULATIONS AND STANDARDS.

**ANY MODIFIED UNITS ARE NON-RETURNABLE**

[ ] As drawn [ ] As marked

Signed: \_\_\_\_\_ Date: \_\_\_\_\_

Printed Name: \_\_\_\_\_

LEAD TIME WILL START UPON RECEIPT OF SIGNED APPROVAL DRAWING

DISTRIBUTOR'S NAME:		P.O.#
VESTIL MANUFACTURING		X
DRAWN BY: MTS	DATE: 03/26/13	W.O.#
REFERENCE: X	SCALE: 1:12	X
QUOTED LEAD TIME: X	QUOTE #	SALES: X
	X	FILE NAME:
		14-007-175