

PALLET TRUCK ROLL ADAPTER - PMRA-20

APPROX WEIGHT: 166.16 lbs. DOES NOT INCLUDE WEIGHT OF POWER OR PACKAGING!!!
 ANY ADDITIONS, DELETIONS, OR OMISSIONS MUST BE CORRECTED ON THIS DRAWING AS THIS DRAWING WILL BE CONSIDERED ALL INCLUSIVE

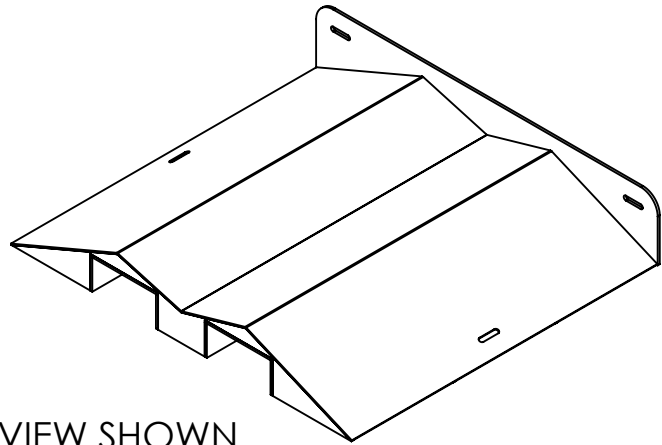

3D VIEW SHOWN FOR REFERENCE ONLY

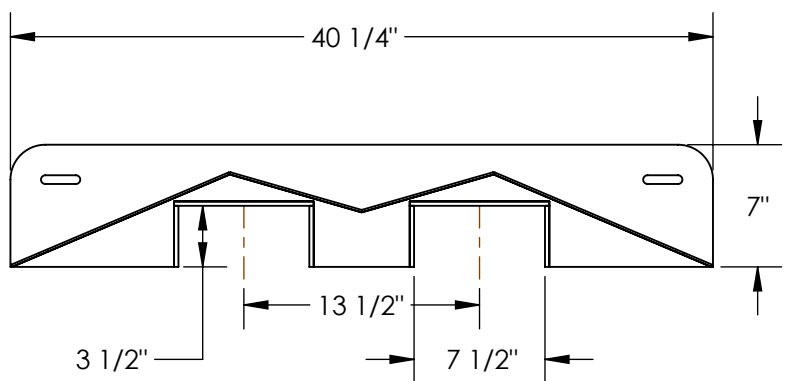
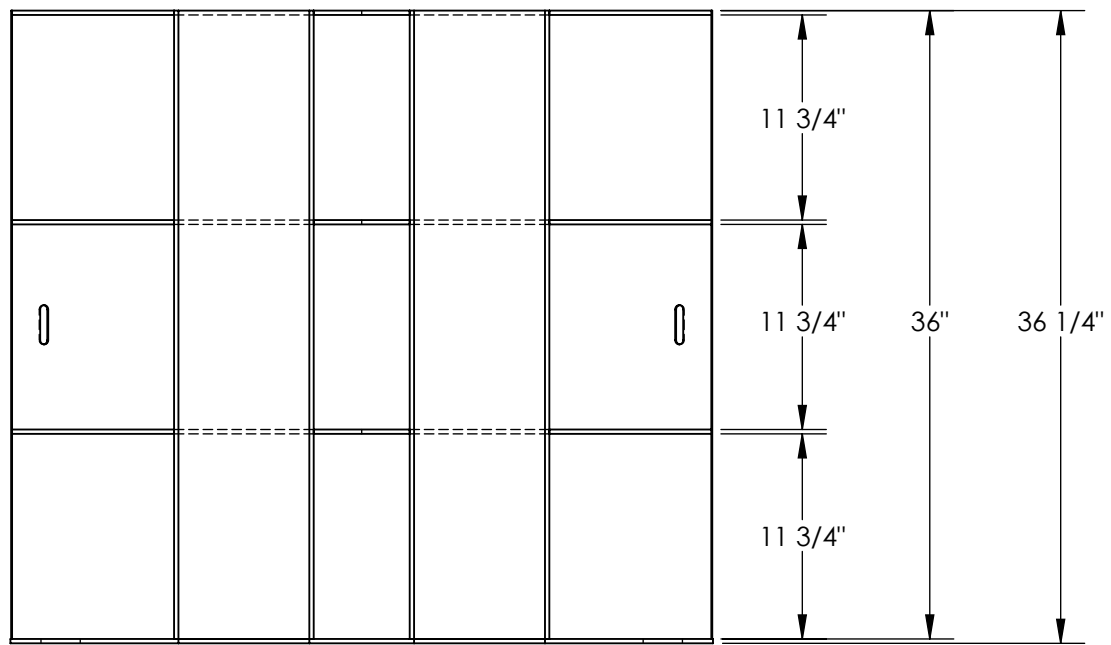

ALL GRAPHICS PROVIDED ARE FOR REFERENCE ONLY. IF CERTAIN DIMENSIONS ARE CRITICAL PLEASE VERIFY THOSE DIMENSIONS WITH YOUR SALESPERSON

STANDARD FEATURES

- MODEL NUMBER IS PMRA-20
- MAX CAPACITY IS 4,000 LBS.
- OVERALL WIDTH IS 40 1/4"
- USABLE WIDTH IS 40 1/4"
- OVERALL LENGTH IS 36 1/4"
- USABLE LENGTH IS 36"
- OVERALL HEIGHT IS 7"
- USABLE FORK POCKETS IS 7-1/2" W X 3-1/2" H
- FORK CENTERS IS 13 1/2"

SPECIAL FEATURES

NONE

| | | |
|--|--|-------------|
| A P P R O V A L | I, THE UNDERSIGNED, AGREE THAT THE PRODUCT AS REPRESENTED SATISFIES DESIGN AND DIMENSION REQUIREMENTS. I ALSO ACKNOWLEDGE MY DUTY TO CONFIRM PRODUCT AND INSTALLATION COMPLIANCE WITH ALL APPLICABLE FEDERAL, STATE AND LOCAL REGULATIONS AND STANDARDS. | |
| | ANY MODIFIED UNITS ARE NON-RETURNABLE | |
| | [] As drawn [] As marked | |
| | Signed: _____ | Date: _____ |
| Printed Name: _____ | | |
| LEAD TIME WILL START UPON RECEIPT OF SIGNED APPROVAL DRAWING | | |

| | | | | |
|---|--|----------------------|---------------|------------|
| FOR INTERNAL USE ONLY PROJECT SIGN OFF | | DISTRIBUTOR'S NAME: | | P.O.# |
| | | VESTIL MANUFACTURING | | X |
| SALES | | DRAWN BY: ND | DATE: 11/3/11 | W.O.# |
| ENG. | | REFERENCE: X | SCALE: 1:11 | X |
| FAB. | | QUOTED LEAD TIME: X | QUOTE # X | SALES: X |
| POWER | | | | FILE NAME: |
| | | | | 33-007-230 |