

DOUBLE SIDED PORTABLE REEL RACK BASE - RERC-CT-3610

APPROX WEIGHT: 583.14 lbs.
 DOES NOT INCLUDE WEIGHT OF POWER OR PACKAGING!!!

ANY ADDITIONS, DELETIONS, OR OMISSIONS MUST BE CORRECTED ON THIS DRAWING AS THIS DRAWING WILL BE CONSIDERED ALL INCLUSIVE

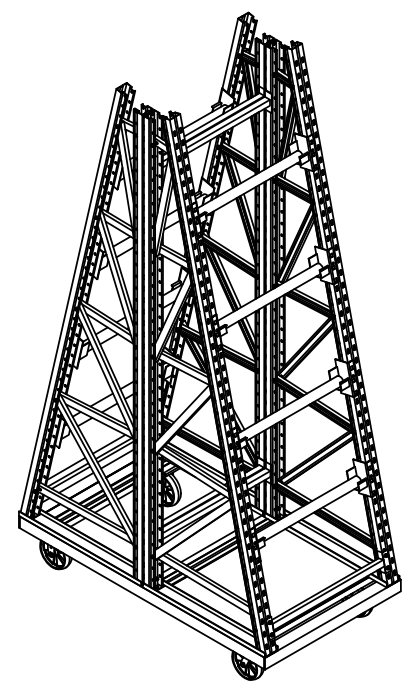
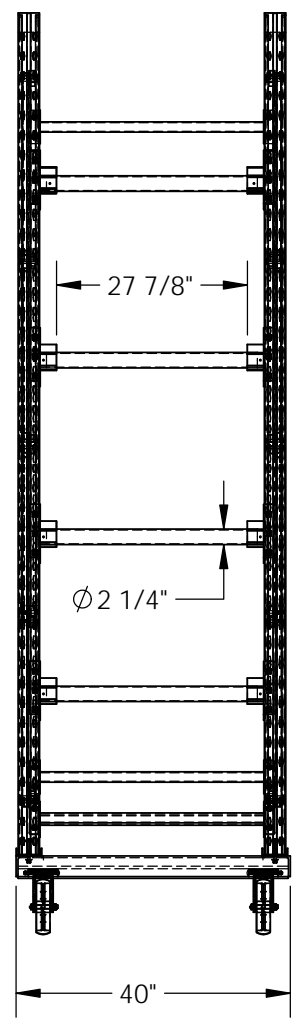
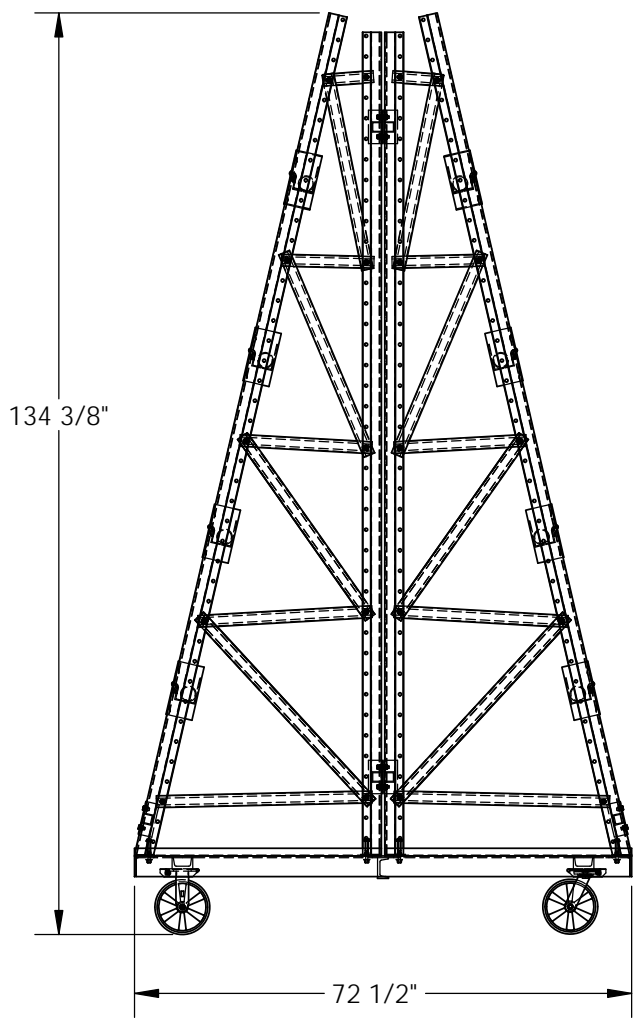

FOR INTERNAL USE ONLY PROJECT SIGN OFF	
SALES	
ENG.	
FAB.	
POWER	

ALL GRAPHICS PROVIDED ARE FOR REFERENCE ONLY. IF CERTAIN DIMENSIONS ARE CRITICAL PLEASE VERIFY THOSE DIMENSIONS WITH YOUR SALESPERSON

DIMENSION TOLERANCE ± 1/2"

STANDARD FEATURES

- MODEL NUMBER IS RERC-CT-3610
- CAPACITY IS 4,000 LBS.
- OVERALL WIDTH IS 40"
- USABLE WIDTH IS 2 1/4"
- OVERALL LENGTH IS 72 1/2"
- USABLE LENGTH IS 27 7/8"
- OVERALL HEIGHT IS 134 3/8"
- USABLE REEL SIZE IS Ø2 1/4" X 27 7/8"LG

SPECIAL FEATURES

NONE

APPROVAL	I, THE UNDERSIGNED, AGREE THAT THE PRODUCT AS REPRESENTED SATISFIES DESIGN AND DIMENSION REQUIREMENTS. I ALSO ACKNOWLEDGE MY DUTY TO CONFIRM PRODUCT AND INSTALLATION COMPLIANCE WITH ALL APPLICABLE FEDERAL, STATE AND LOCAL REGULATIONS AND STANDARDS.	
	ALL SPECIAL UNITS ARE NON-RETURNABLE	
	[] As drawn [] As marked	
Signed: _____		Date: _____
LEAD TIME WILL START UPON RECEIPT OF SIGNED APPROVAL DRAWING		

DISTRIBUTOR'S NAME:		P.O.#
VESTIL MANUFACTURING		X
DRAWN BY: CA		W.O.#
DATE: 09/22/2015		X
REFERENCE: X	SCALE: 1:28	SALES: X
QUOTED LEAD TIME: X	QUOTE #	FILE NAME:
	X	31-007-222