

PORTABLE UNI-TILTS - UNI-P-5448-4

APPROX WEIGHT: 1527.84 lbs.
DOES NOT INCLUDE WEIGHT OF POWER OR PACKAGING!!!

*** ANY ADDITIONS, DELETIONS, OR OMISSIONS MUST BE CORRECTED ON THIS DRAWING AS THIS DRAWING WILL BE CONSIDERED ALL INCLUSIVE ***
ALL GRAPHICS PROVIDED ARE FOR REFERENCE ONLY. IF CERTAIN DIMENSIONS ARE CRITICAL PLEASE VERIFY THOSE DIMENSIONS WITH YOUR SALESPERSON

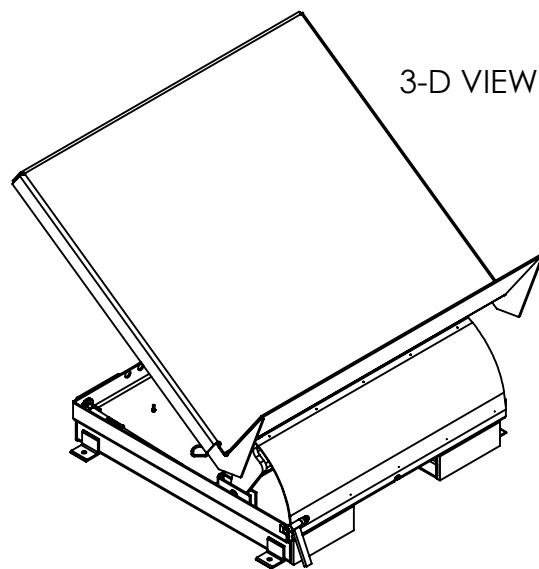

3-D VIEW

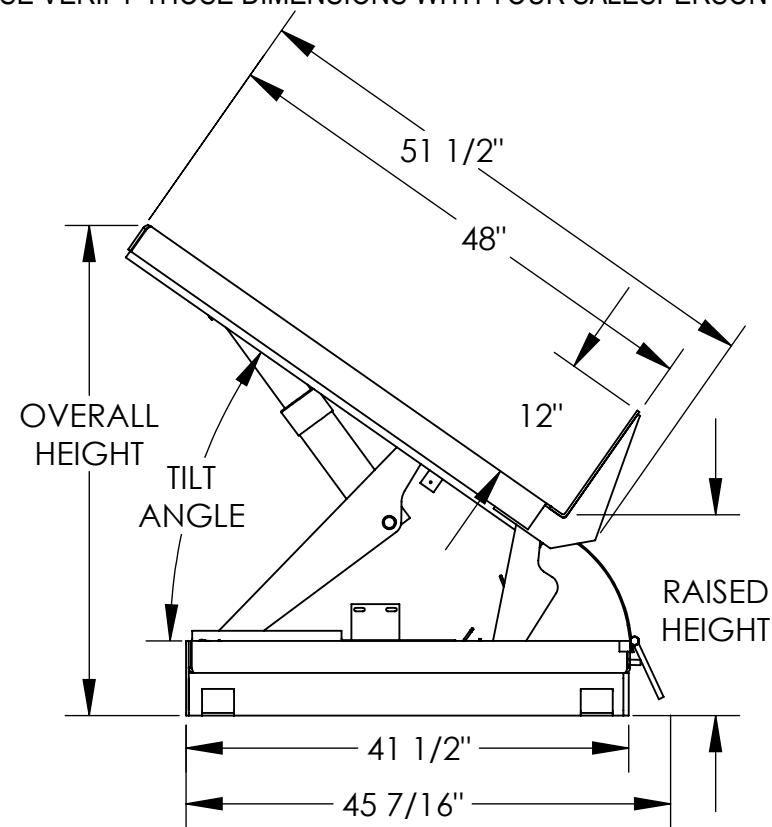
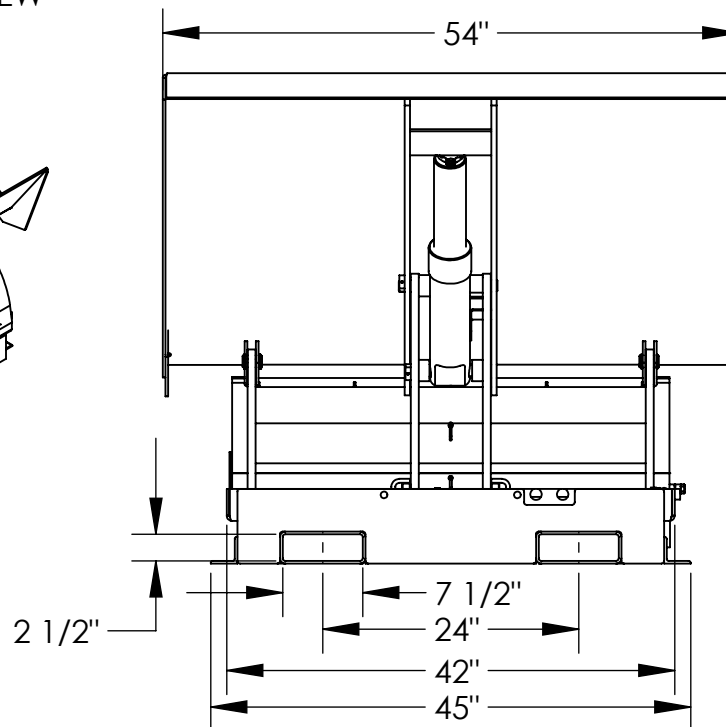

DIMENSION TOLERANCE ± 1/4"

STANDARD FEATURES

- MODEL NUMBER IS: UNI-P-5448-4
- CAPACITY: 4,000 LBS. EVENLY DISTRIBUTED
- SEQUENCE 1: RAISED HEIGHT: 18 3/4", TILT ANGLE 35°
OVERALL HEIGHT: 46"
- SEQUENCE 2: RAISED HEIGHT 15 3/4", TILT ANGLE: 40°
OVERALL HEIGHT 46 1/4"
- LEVEL HEIGHT: 12"

- DECK SIZE: 54" W X 48" L WITH 12" LIP
- INTEGRAL MAINTENANCE LOCK
- UPPER TRAVEL LIMIT SWITCH
- USABLE FORK POCKETS: 2-1/2" H X 7-1/2" W WITH 24" FORK CENTERS
- DURABLE LIQUID PAINT BLUE FINISH

SPECIAL FEATURES

NONE

PLEASE CIRCLE SPECIFICATIONS:

POWER	<input checked="" type="checkbox"/> AC	<input type="checkbox"/> DC	<input type="checkbox"/> AIR/OIL
MOTOR VOLTAGE	<input type="checkbox"/> 115	<input type="checkbox"/> 208	<input checked="" type="checkbox"/> 230 460
DEDICATED CIRCUIT REQUIRED			
MOTOR PHASE	<input type="checkbox"/> SINGLE	<input checked="" type="checkbox"/> THREE	
CONTROL	<input checked="" type="checkbox"/> HAND	<input type="checkbox"/> FOOT	
~ ALL BATTERY CHARGERS ARE 115V AC ~			
* BATTERY CHRG.	<input type="checkbox"/> REMOTE	<input checked="" type="checkbox"/> ON-BOARD	
* CHRG. INDICATOR	<input checked="" type="checkbox"/> YES	<input type="checkbox"/> NO	

* AVAILABLE AT ADDITIONAL COST

APPROVAL

I, THE UNDERSIGNED, AGREE THAT THE PRODUCT AS REPRESENTED SATISFIES DESIGN AND DIMENSION REQUIREMENTS. I ALSO ACKNOWLEDGE MY DUTY TO CONFIRM PRODUCT AND INSTALLATION COMPLIANCE WITH ALL APPLICABLE FEDERAL, STATE AND LOCAL REGULATIONS AND STANDARDS.
UNITS REQUIRING APPROVAL DRAWINGS OR MODIFIED ARE NON-RETURNABLE
[] As drawn [] As marked

Signed: _____ Date: _____

Printed Name: _____

LEAD TIME WILL START UPON RECEIPT OF SIGNED APPROVAL DRAWING

DISTRIBUTOR'S NAME: _____ P.O.# X

VESTIL MANUFACTURING W.O.# X

DRAWN BY: A. FORD DATE: 8/10/07 SALES: X

REFERENCE: X SCALE: 1:18 FILE NAME:

QUOTED LEAD TIME: X QUOTE # X 03-007-041