

PORTABLE ALUM. VEHICLE TWIN RAMPS - VTR-5.5-14-20

APPROX WEIGHT: 837.08 lbs.
DOES NOT INCLUDE WEIGHT OF POWER OR PACKAGING!!!

*** ANY ADDITIONS, DELETIONS, OR OMISSIONS MUST BE CORRECTED ON THIS DRAWING AS THIS DRAWING WILL BE CONSIDERED ALL INCLUSIVE ***

ALL GRAPHICS PROVIDED ARE FOR REFERENCE ONLY. IF CERTAIN DIMENSIONS ARE CRITICAL PLEASE VERIFY THOSE DIMENSIONS WITH YOUR SALESPERSON

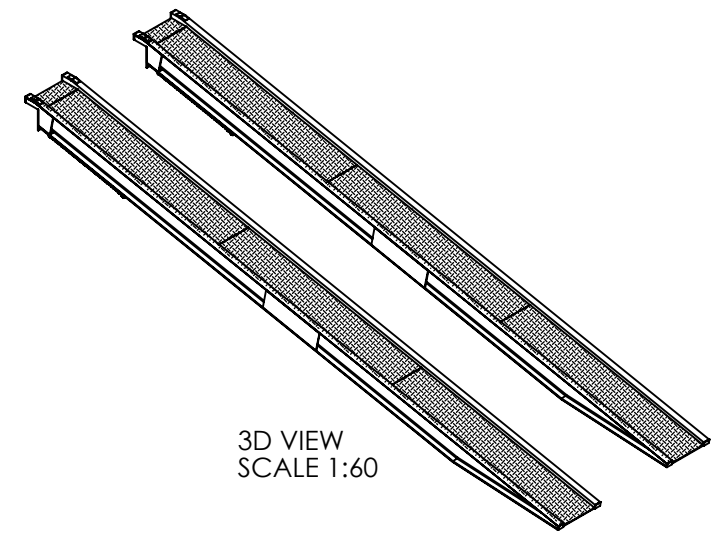
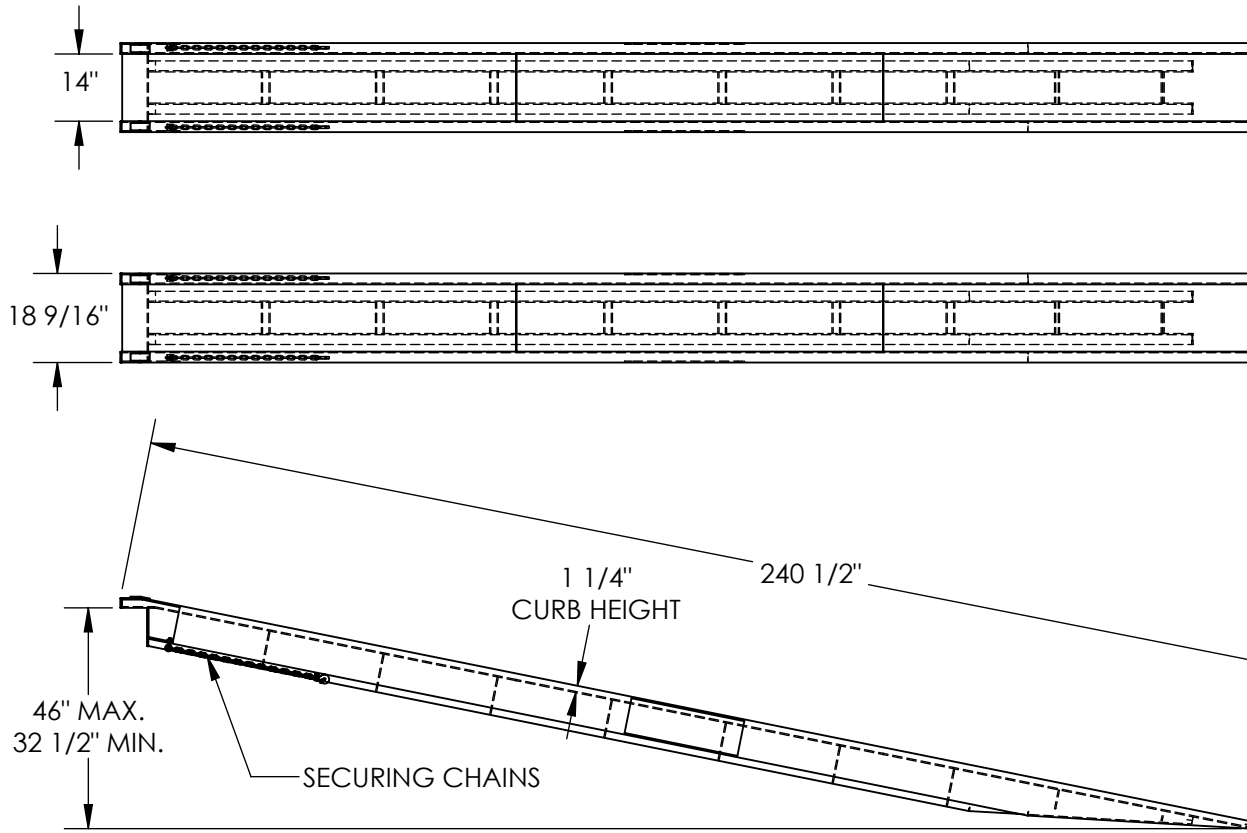

DIMENSION TOLERANCE ± 1/4"

STANDARD FEATURES

- MODEL NUMBER IS VTR-5.5-14-20
- OVERALL WIDTH IS 18 9/16"
- USABLE RAMP WIDTH IS 14"
- LENGTH IS 240 1/2"
- MAX. WORKING HEIGHT IS 46"
- MIN. WORKING HEIGHT IS 32 1/2"
- MAX. LOAD CAPACITY (PER PAIR) IS 5,500 LBS.
- INCLUDES 2 SECURING CHAINS
- WELDED ALUMINUM CONSTRUCTION

SPECIAL FEATURES

NONE

A P P R O V A L

I, THE UNDERSIGNED, AGREE THAT THE PRODUCT AS REPRESENTED SATISFIES DESIGN AND DIMENSION REQUIREMENTS. I ALSO ACKNOWLEDGE MY DUTY TO CONFIRM PRODUCT AND INSTALLATION COMPLIANCE WITH ALL APPLICABLE FEDERAL, STATE AND LOCAL REGULATIONS AND STANDARDS.

ANY MODIFIED UNITS ARE NON-RETURNABLE

As drawn As marked

Signed: _____ Date: _____

Printed Name: _____

LEAD TIME WILL START UPON RECEIPT OF SIGNED APPROVAL DRAWING

FOR INTERNAL USE ONLY PROJECT SIGN OFF	
SALES	
ENG.	
FAB.	
POWER	

DISTRIBUTOR'S NAME: VESTIL MANUFACTURING		P.O.# X
DRAWN BY: TJM		W.O.# X
DATE: 11/14/14	SALES: X	FILE NAME: 18-007-306
REFERENCE: X	SCALE: 1:40	
QUOTED LEAD TIME: X	QUOTE # X	