

EXTRUDED ALUMINUM HOSE & CABLE CROSSOVER RAMP - WR-24-BRN

APPROX WEIGHT: 0.94 lbs.
DOES NOT INCLUDE WEIGHT OF POWER OR PACKAGING!!!

*** ANY ADDITIONS, DELETIONS, OR OMISSIONS MUST BE CORRECTED ON THIS DRAWING AS THIS DRAWING WILL BE CONSIDERED ALL INCLUSIVE ***
ALL GRAPHICS PROVIDED ARE FOR REFERENCE ONLY. IF CERTAIN DIMENSIONS ARE CRITICAL PLEASE VERIFY THOSE DIMENSIONS WITH YOUR SALESPERSON

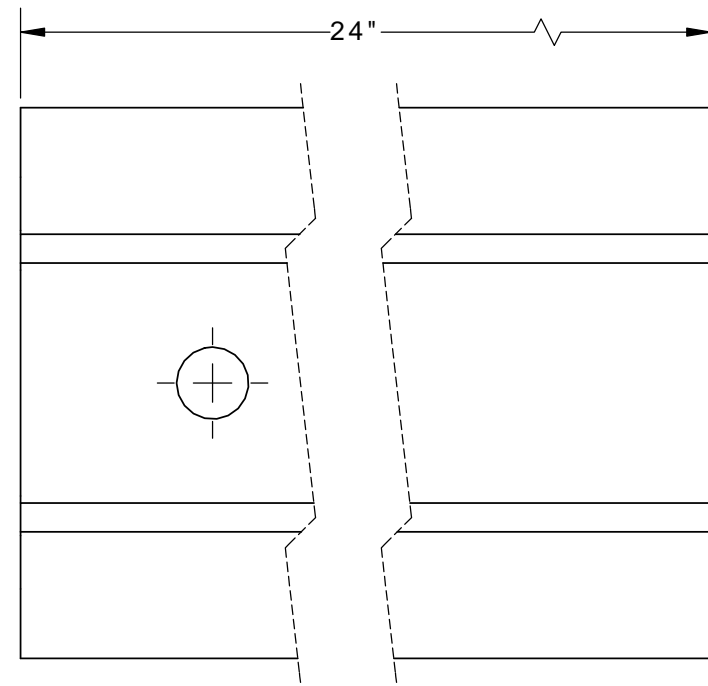
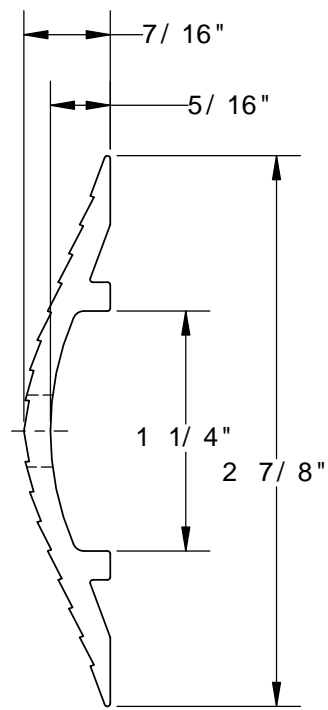

NOTE: HOLE IS FOR POWDER COATED UNITS ONLY

STANDARD FEATURES

- MODEL NUMBER: WR-24-BRN
- SINGLE WHEEL CAPACITY: 2,500 LBS
- OVERALL WIDTH: 2 7/8"
- OVERALL LENGTH: 24"
- OVERALL HEIGHT: 7/16"
- USABLE WIDTH: 1 1/4"
- USABLE HEIGHT: 5/16"
- FINISH: BROWN

SPECIAL FEATURES

NONE

DIMENSION TOLERANCE ± 1/2"

APPROVAL	I, THE UNDERSIGNED, AGREE THAT THE PRODUCT AS REPRESENTED SATISFIES DESIGN AND DIMENSION REQUIREMENTS. I ALSO ACKNOWLEDGE MY DUTY TO CONFIRM PRODUCT AND INSTALLATION COMPLIANCE WITH ALL APPLICABLE FEDERAL, STATE AND LOCAL REGULATIONS AND STANDARDS.	
	ANY MODIFIED UNITS ARE NON-RETURNABLE	
	[] As drawn [] As marked	
	Signed: _____	Date: _____
Printed Name: _____		LEAD TIME WILL START UPON RECEIPT OF SIGNED APPROVAL DRAWING

FOR INTERNAL USE ONLY PROJECT SIGN OFF	
SALES	
ENG.	
FAB.	
POWER	

DISTRIBUTOR'S NAME:		P.O.#
VESTIL MANUFACTURING		X
DRAWN BY: K.YEAKLE		W.O.#
DATE: 05/09/12		X
REFERENCE: X	SCALE: 1:8	SALES: X
QUOTED LEAD TIME: X	QUOTE #	FILE NAME:
	X	29-007-040-002